

Premium Terrassendach 9x3 m bis 10x5 m

- Ⓛ Montageanleitung
- Ⓜ Assembly instructions
- Ⓝ Instructions de montage

Nr.: 9219129

Art.-Nr. 4295301-4295371

4295515-4295585

4295731-4295799

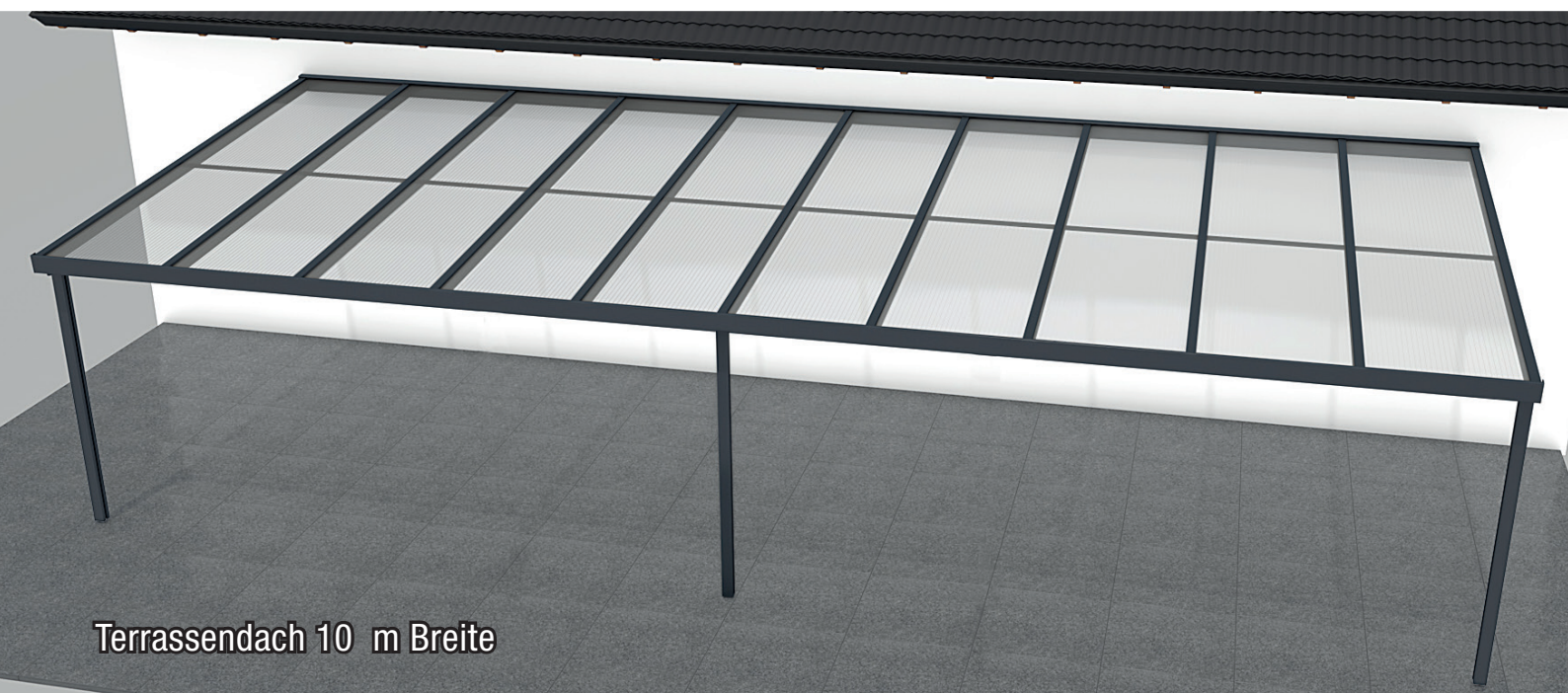
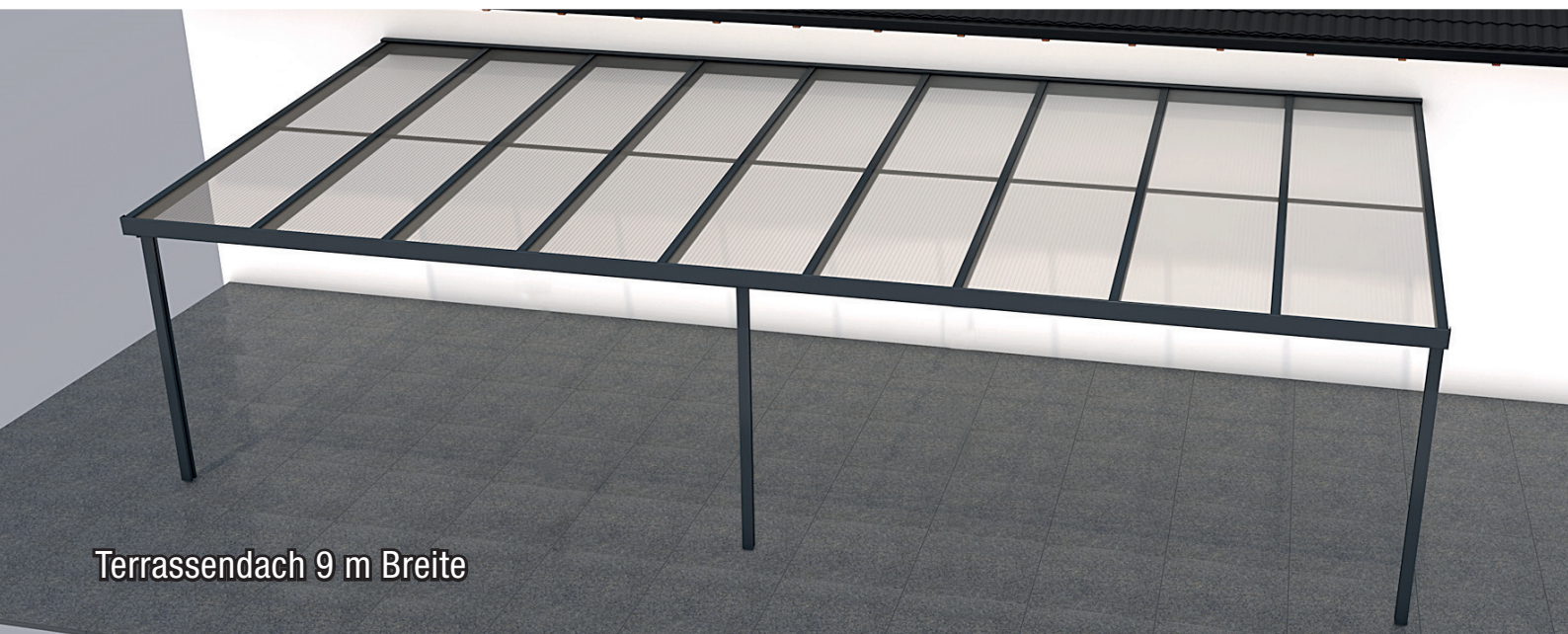

gulta[®]

- Lesen Sie alle Sicherheitshinweise und Anweisungen. Versäumnisse bei der Einhaltung können schwere Verletzungen verursachen.
- Beachten Sie die örtlichen Bauvorschriften sowie die Schneelastzonen in ihrer Region.
- Offenes Feuer, leichtentzündlichen Stoffen oder dergleichen ist unterhalb des Produktes nicht erlaubt. Fluchtwege müssen vorhanden und freigehalten werden.
- Sortieren Sie die Teile vor der Montage und prüfen Sie die Inhaltsliste gemäß Montageanleitung.
- Zur Montage des Terrassendach-Bausatzes werden mindestens 2 Personen benötigt.
- Befolgen Sie die Anweisungen und Montageschritte in der Montageanleitung.
- Die Hohlkammerplatten dürfen nicht ohne quergelegte Laufbretter (über mind. 2 Sparren) begangen werden.
- Punktbelastungen sind unbedingt zu vermeiden.
- Entfernen Sie regelmäßig den Schnee vom Dach. Eine Schneehöhe von mehr als 10 cm kann bereits gefährlich werden (Schichthöhen von 36 cm bei trockenem Schnee, 10 cm bei wässrigem Schnee und 5,5 cm bei Eis entsprechen einem Gewicht von ca. 50 kg/m²).
- Schneelast: Modelle mit 3-4 m Dachtiefe: 150 kg/m² und Modelle mit 5 m Dachtiefe: 100 kg/m².
- Enthaltene Befestigungsmaterial ist nur für festes Mauerwerk. Bei Dämmung, Hohlblöcken etc. muss separates Befestigungsmaterial verwendet werden.
- Halten Sie die Dachrinne frei von Laub, Schmutz und Schnee.
- Der Terrassendach muss auf einem ebenen, festen Untergrund (z. Beton, Betonplatten) montiert werden.
Fundamentmaße: Länge 40 cm x Breite 40 cm x Tiefe 80 cm
- Reinigen Sie die Hohlkammerplatten mit Wasser und einem milden Reinigungsmittel, verwenden Sie keine Scheuermittel, Aceton oder lösungshaltige Mittel!
- Defekte oder verbogene Pfosten oder Träger sind sofort auszutauschen.
- **Das Wandanschlussprofil muss in folgender Höhe angebracht werden (gemessen an der Profilerkante).**
 - 3 m Tiefe: 240 cm = 7° - 300 cm = 20°
 - 4 m Tiefe: 240 cm = 5° - 340 cm = 20°
 - 5 m Tiefe: 245 cm = 5° - 375 cm = 20°
- Da der Querträger um max. 60cm Richtung Hauswand versetzt werden kann, ergibt sich daraus eine höhere Dachneigung (Gefälle).

Farb- und Größenabweichungen etc. innerhalb der üblichen Toleranzen vorbehalten. Unsere Empfehlungen befreien nicht von der Verpflichtung, das Produkt eigenverantwortlich zu überprüfen. Im Zweifelsfalle bitten wir eine Fachberatung in Anspruch zu nehmen. Technische Änderungen vorbehalten.

Das Premium Terrassendach wurde gem. der EN 1090 entwickelt und hergestellt. Es darf nur für Überdachungen einer Terrasse mit entsprechender Befestigung für die jeweilige Hauswand und für nicht gewerbliche Anwendung genutzt werden. Jede andere als die hier beschriebene bestimmungsgemäße Verwendung gilt als zweckwidrige Verwendung. Der Hersteller haftet nicht für eventuelle Schäden oder Folgeschäden, die durch zweckwidrige, falsche oder unsachgemäße Verwendung entstehen.



Konformitätserklärung:

Produkte, die mit diesem Symbol gekennzeichnet sind, erfüllen alle geltenden Bestimmungen des Europäischen Wirtschaftsraums.

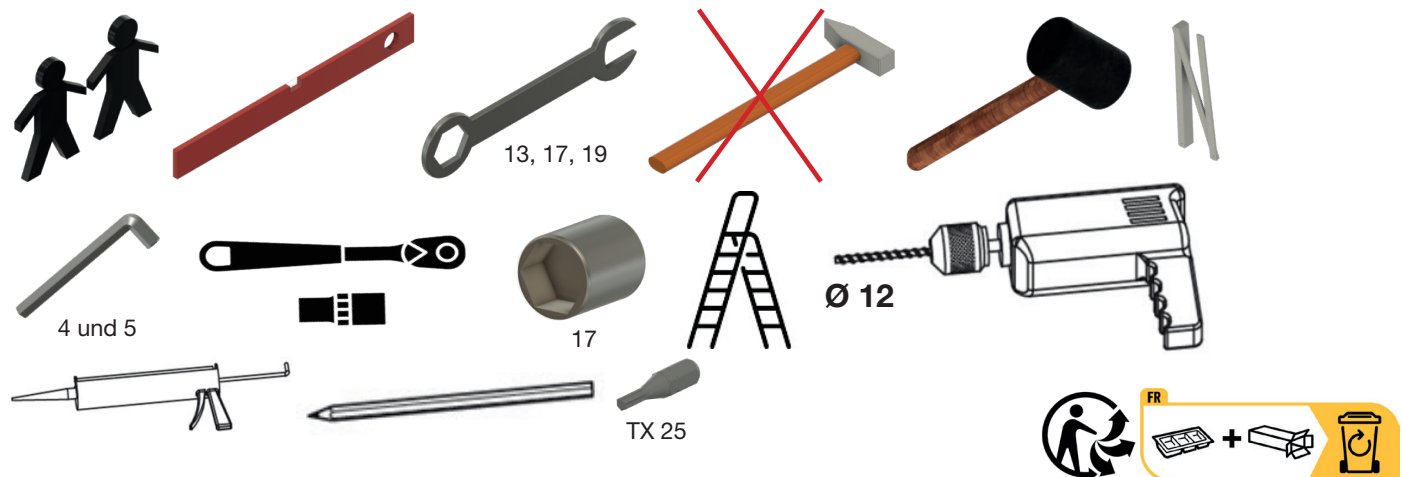

- Read all safety notices and instructions. Failure to do so may result in serious cause serious injury.
- Observe the local building regulations as well as the snow load zones in your region.
- Open fire, highly flammable substances or the like are not permitted underneath the product. Escape routes must be available and kept clear.
- Sort the parts before assembly and check the contents list according to the assembly instructions.
- At least 2 persons are required to assemble the patio roof kit.
- Follow the instructions and assembly steps in the assembly instructions.
- The twin-wall sheets must not be walked on without crosswise running boards (over at least 2 rafters).
- Point loads must be avoided at all costs.
- Remove snow from the roof regularly. A snow height of more than 10 cm can already become dangerous (layer heights of 36 cm for dry snow, 10 cm for watery snow and 5.5 cm for ice correspond to a weight of approx. 50 kg/m²).
- Snow load: models with 3-4 m roof depth: 150 kg/m² and models with 5 m roof depth: 100 kg/m².
- Included fastening material is for solid masonry only. Separate fasteners must be used for insulation, hollow blocks, etc.
- Keep the gutter free of leaves, dirt and snow.
- The patio roof must be mounted on a level, solid foundation (e.g. concrete, concrete slabs).
Foundation dimensions: length 40 cm x width 40 cm x depth 80 cm.
- Clean the twin-wall sheets with water and a mild detergent, do not use abrasives, acetone or solvents!
- Defective or bent posts or beams must be replaced immediately.
- The wall connection profile must be attached at the following height (measured at the upper edge of the profile).
 3 m depth: 240 cm = 7° - 300 cm = 20°
 4 m depth: 240 cm = 5° - 340 cm = 20°
 5 m depth: 245 cm = 5° - 375 cm = 20°
- As the cross beam can be moved by max. 60cm towards the house wall, this results in a higher roof pitch (slope).

Colour and size deviations etc. within the usual tolerances reserved. Our recommendations do not release the customer from the obligation to check the product on his own responsibility. In case of doubt, please consult a specialist. Technical modifications reserved.

The Premium Terrace Roof has been developed and manufactured according to EN 1090. It may only be used for roofing over a terrace with appropriate fastening for the respective house wall and for non-commercial use. Any use other than the intended use described here is considered improper use. The manufacturer is not liable for any damage or consequential damage resulting from improper, incorrect or inappropriate use.

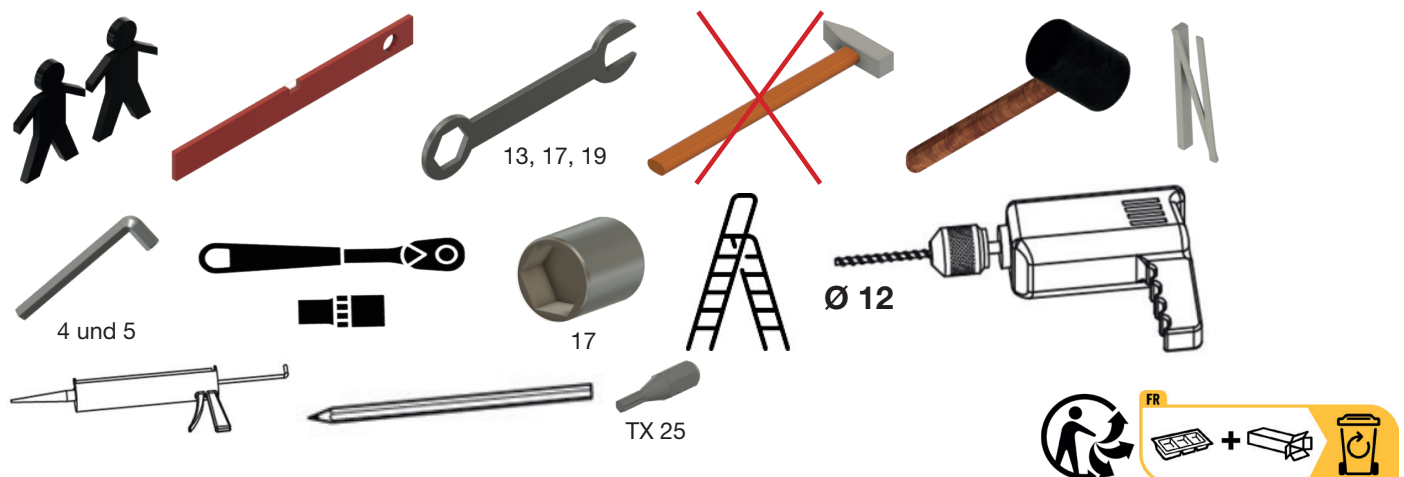

- Lisez toutes les consignes de sécurité et les instructions. Le non-respect de ces consignes peut entraîner de graves provoquer des blessures.
- Respectez les réglementations locales en matière de construction et les zones de charge de neige de votre région.
- Les flammes nues, les substances facilement inflammables ou autres ne sont pas autorisées sous le produit. Les voies d'évacuation doivent être disponibles et dégagées.
- Triez les pièces avant le montage et vérifiez la liste de contenu conformément aux instructions de montage.
- Le montage du kit de toit de terrasse nécessite au moins deux personnes.
- Suivez les instructions et les étapes de montage de la notice de montage.
- Il ne faut pas marcher sur les panneaux alvéolaires sans avoir posé de planches de roulement en travers (sur au moins 2 chevrons).
- Les charges ponctuelles doivent absolument être évitées.
- Enlevez régulièrement la neige du toit. Une hauteur de neige de plus de 10 cm peut déjà être dangereuse (des hauteurs de couche de 36 cm pour la neige sèche, de 10 cm pour la neige aqueuse et de 5,5 cm pour la glace correspondent à un poids d'environ 50 kg/m²).
- Charge de neige : modèles avec une profondeur de toit de 3-4 m : 150 kg/m² et modèles avec une profondeur de toit de 5 m : 100 kg/m².
- Le matériel de fixation inclus est uniquement destiné à la maçonnerie solide. En cas d'isolation, de blocs creux, etc., il faut utiliser un matériel de fixation séparé.
- Veillez à ce que la gouttière soit exempte de feuilles, de saletés et de neige.
- Le toit de terrasse doit être monté sur une base plane et solide (par ex. béton, dalles de béton).
Dimensions de la fondation : longueur 40 cm x largeur 40 cm x profondeur 80 cm.
- Nettoyez les plaques alvéolaires avec de l'eau et un détergent doux, n'utilisez pas de produits abrasifs, d'acétone ou de produits contenant des solvants !
- Les poteaux ou supports défectueux ou déformés doivent être remplacés immédiatement.
- Le profilé de raccordement mural doit être placé à la hauteur suivante (mesurée au niveau du bord supérieur du profil).

3 m de profondeur :	240 cm = 7°	- 300 cm = 20°
4 m de profondeur :	240 cm = 5°	- 340 cm = 20°
5 m de profondeur :	245 cm = 5°	- 375 cm = 20°
- Comme la traverse peut être décalée de 60cm maximum en direction du mur de la maison, il en résulte une pente de toit plus élevée (inclinaison).

Les écarts de couleur et de dimension dans les tolérances habituelles sont réputés dans la norme d'acceptation. Nos recommandations ne vous dispensent pas d'inspecter le produit sous votre propre responsabilité. En cas de doute, nous conseillons de faire appel à un professionnel. Sous réserve de modifications techniques.

Le Premium Terrace Roof a été développé et fabriqué conformément à la norme EN 1090. Il ne peut être utilisé que pour la couverture d'une terrasse avec une fixation appropriée pour le mur de la maison concernée et pour un usage non commercial. Toute utilisation autre que l'usage prévu décrit ici est considérée comme une utilisation abusive. Le fabricant n'est pas responsable des dommages ou des dommages consécutifs résultant d'une utilisation incorrecte ou inappropriée.

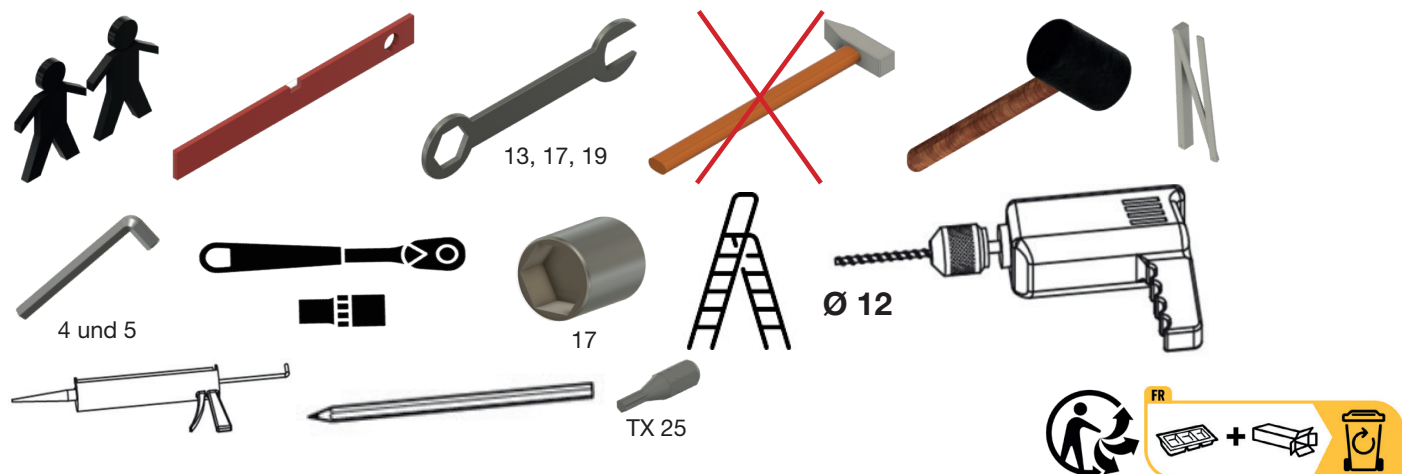

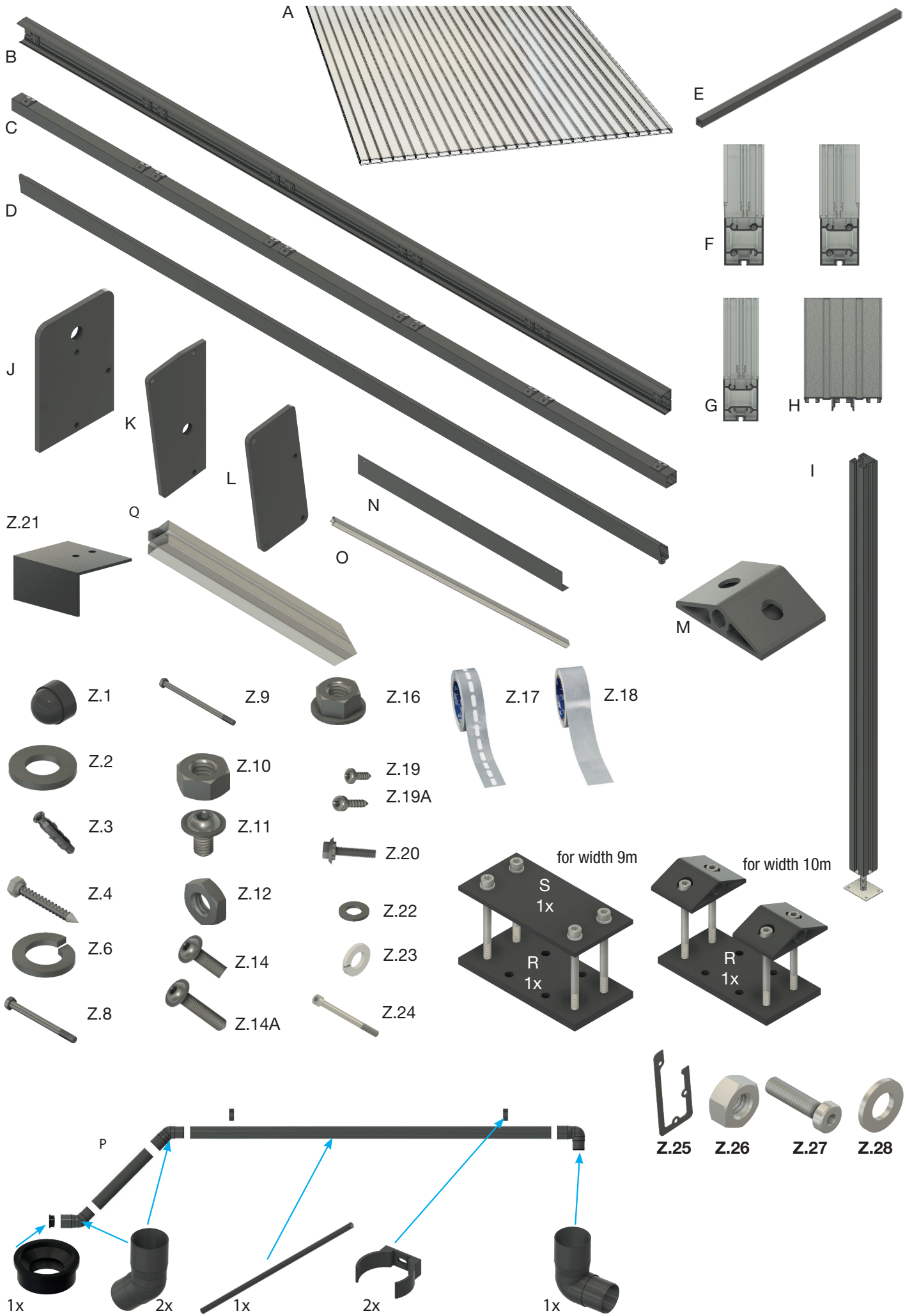

Nr.	Bezeichnung	Designation
A	Hohlkammerplatte 980 x 3000 - 5000 mm	Twinwall sheet 980 x 3000 - 5000 mm
B	Wandanschluss inkl. vormontierter Lagerprofile	Wall connection incl. pre-assembled bearing profiles
C	Vorderer Querträger / Pfette	Front cross beam / purlin
D	Regenrinne	Rain gutter
E	Querstrebe 30x30x946 mm	Cross brace 30x30x946 mm
F	Sparren Rand links und rechts (teilmontiert)	Rafter Edge left and right (partly pre-assembled)
G	Sparren Mitte (teilmontiert)	Rafter middle (partly pre-assembled)
H	Alu Deckel	Alu Cap
I	Pfosten vormontiert mit Standfuß	Pre-assembled post with stand
J	Deckel Vorderer Querträger / Pfette	Cap of front cross beam / purlin
K	Deckel Wandanschluss	Cap wall connection
L	Deckel Regenrinne	Cap rain gutter
M	Lagerprofil	Storage profil
N	Abdeckung Wandanschluss	Cover of wall connection
O	U-Profil für Hohlkammerplatten	U-Profil for Twinwall sheets
P	Regenablauf	Rain drainage
Q	Pfettenverstärkung • bereits vormontiert!	Purlin reinforcement for size 5x3 / 5x4 • already pre-assembled!
R	Untere Verbindungsplatte inkl. obere Lagerprofile	Lower connecting plate incl. top bearing profiles
S	Obere Verbindungsplatte	Upper connecting plate
Z.1	Abdeckkappe SW 19	Cover cap SW 19
Z.2	10,5 VZ DIN 125	10,5 VZ DIN 125
Z.3	Dübel 12 mm	Dübel 12 mm
Z.4	10x80 VZ DIN 571	10x80 VZ DIN 571
Z.6	M12 DIN 127 B VZ	M12 DIN 127 B VZ
Z.8	M12x140 DIN 931 8.8	M12x140 DIN 931 8.8
Z.9	M12x200 DIN 931 8.8	M12x200 DIN 931 8.8
Z.10	M6 DIN 439	M6 DIN 439
Z.11	M6x10 ISO 7380-2 10.9	M6x10 ISO 7380-2 10.9
Z.12	M12 DIN 934 VZ	M12 DIN 934 VZ
Z.14	M8x25 ISO 738 Stahl 010.9 verzinkt	M8x25 ISO 738 Stahl 010.9 verzinkt
Z.14A	M8x40 ISO 738 Stahl 010.9 verzinkt	M8x40 ISO 738 Stahl 010.9 verzinkt
Z.16	M8 DIN 1661 A2	M8 DIN 1661 A2
Z.17	Kantenverschußband mit Membrane	Edge closing tape with membrane
Z.18	Kantenverschußband ohne Membrane (nur bei Acryl)	Edge closing tape without membrane (only with acrylic)
Z.19	4,8x13 ISO 14585 A2 TX C	4,8x13 ISO 14585 A2 TX C
Z.19 A	4,8x25 ISO 14585	4,8x25 ISO 14585
Z.20	Edelstahlschraube 6,3x32 inkl. Membrandichtung	Stainless steel screw 6,3x32 incl. membrane seal
Z.21	Winkel	Angel
Z.22	U-Scheibe M8	Washer M8
Z.23	WUERTH 04478 Sprengring DIN 127 B8 A2 BLK	WUERTH 04478 snap ring DIN 127 B8 A2 BLK
Z.24	Zylinderkopfschraube M8 x 95	Cylinder head screw M8 x 95
Z.25	Rinnenverbinder Dichtung	Gutter connector seal
Z.26	Rinnenverbinder Mutter M5	Gutter connector nut M5
Z.27	Rinnenverbinder Schraube M5	Gutter connector M5 screw
Z.28	Rinnenverbinder U-Scheibe M5	Gutter connector Washer M5

Désignation	9 x 3 m	9 x 4 m	9 x 5 m	10 x 3 m	10 x 4 m	10 x 5 m
Plaque alvéolaire 980 x 3000 - 5000 mm	9x			10x		
Raccordement mural, profilés préassemblés inclus				2x		
Poutre avant / panne				2x		
Gouttière				2x		
Traverse 30x30x946 mm	18x	18x	27x	20x	20x	30x
Chevron latéral droit et gauche (partiellement préassemblé)				2x		
Chevron médian (partiellement préassemblé)	8x			9x		
Recouvrement alu entre plaques	10x			11x		
Poteau préassemblé avec empiètement				3x		
Fermeture de la poutre avant / panne				2x		
Fermeture latérale de raccordement mural				2x		
Fermeture latérale de gouttière				2x		
Profil du camp	10x			11x		
Profilé de recouvrement des raccordements muraux	9x			10x		
Profilé de fermeture pour plaque alvéolaire	18x			20x		
Ecoulement d'eau pluviale				2x		
Renfort de pannes pour taille 5x3 / 5x4 • déjà préassemblé!				2x		
Plaque de connexion inférieure y compris profilés de palier supérieurs				1x		
Plaque de connexion supérieure	1x			-		
Cover cap SW 19				4x		
10,5 VZ DIN 125	32x			34x		
Dübel 12 mm	32x			34x		
10x80 VZ DIN 571	32x			34x		
M12 DIN 127 B VZ	20x			22x		
M12x140 DIN 931 8.8				4x		
M12x200 DIN 931 8.8	16x			18x		
M6 DIN 439	20x			22x		
M6x10 ISO 7380-2 10.9	20x			22x		
M12 DIN 934 VZ	20x			22x		
M8x25 ISO 738 Stahl 010.9 verzinkt				8x		
M8x40 ISO 738 Stahl 010.9 verzinkt				4x		
M8 DIN 1661 A2	20x			22x		
Adhésif de fermeture avec membrane				2x (1x only by acrylic)		
Adhésif de fermeture sans membrane (uniquement pour l'acrylique)				1x		
4,8x13 ISO 14585 A2 TX C	63x			68x		
4,8x25 ISO 14585				12x		
Vis inox 6,3x32 avec joint	60x	80x	100x	66x	88x	110x
Angle	10x			11x		
Rondelle en U M8	-			4x		
WUERTH 04478 bague de serrage DIN 127 B8 A2 BLK				4x		
Vis à tête cylindrique M8 x 95				4x		
Raccord de gouttière Joint				1x		
Raccord de gouttière Écrou M5				3x		
Raccord de gouttière Vis M5				3x		
Raccord de gouttière Rondelle en U M5				6x		

1.

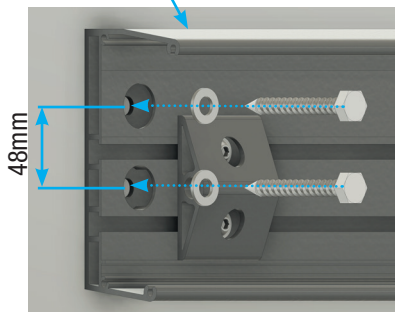
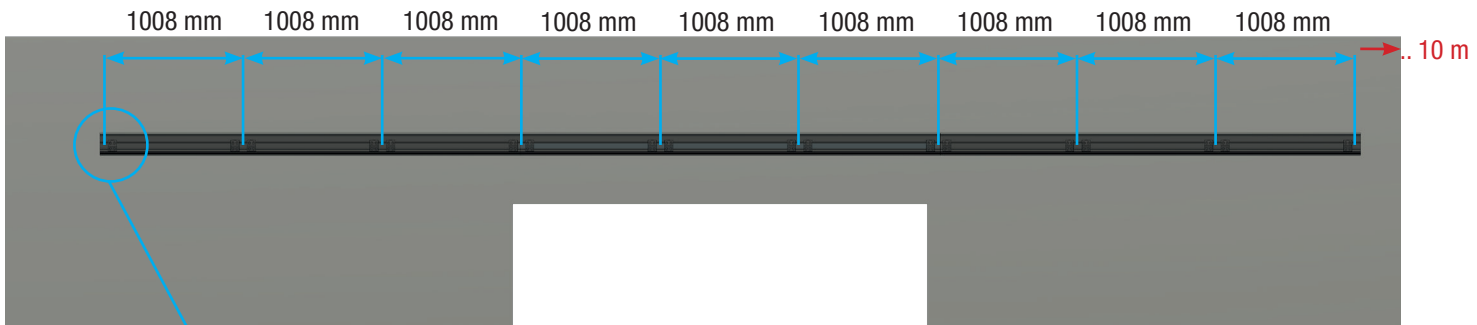
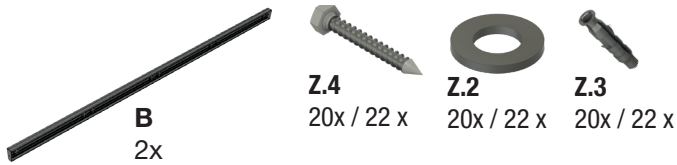

Enthaltenes Befestigungsmaterial ist nur für feste Betonwand. Bei Dämmung, Hohlblöcken etc. muss separates Befestigungsmaterial verwendet werden.

Included fixing material is for solid concrete wall only. Separate fixing material must be used for insulation, hollow blocks, etc.

Le matériel de fixation inclus est uniquement destiné à un mur en béton solide. En cas d'isolation, de blocs creux, etc., il faut utiliser un matériel de fixation séparé.

Meegeleverd bevestigingsmateriaal is alleen voor massieve betonnen muren. Voor isolatie, holle blokken, enz. moet apart bevestigingsmateriaal worden gebruikt.

2.

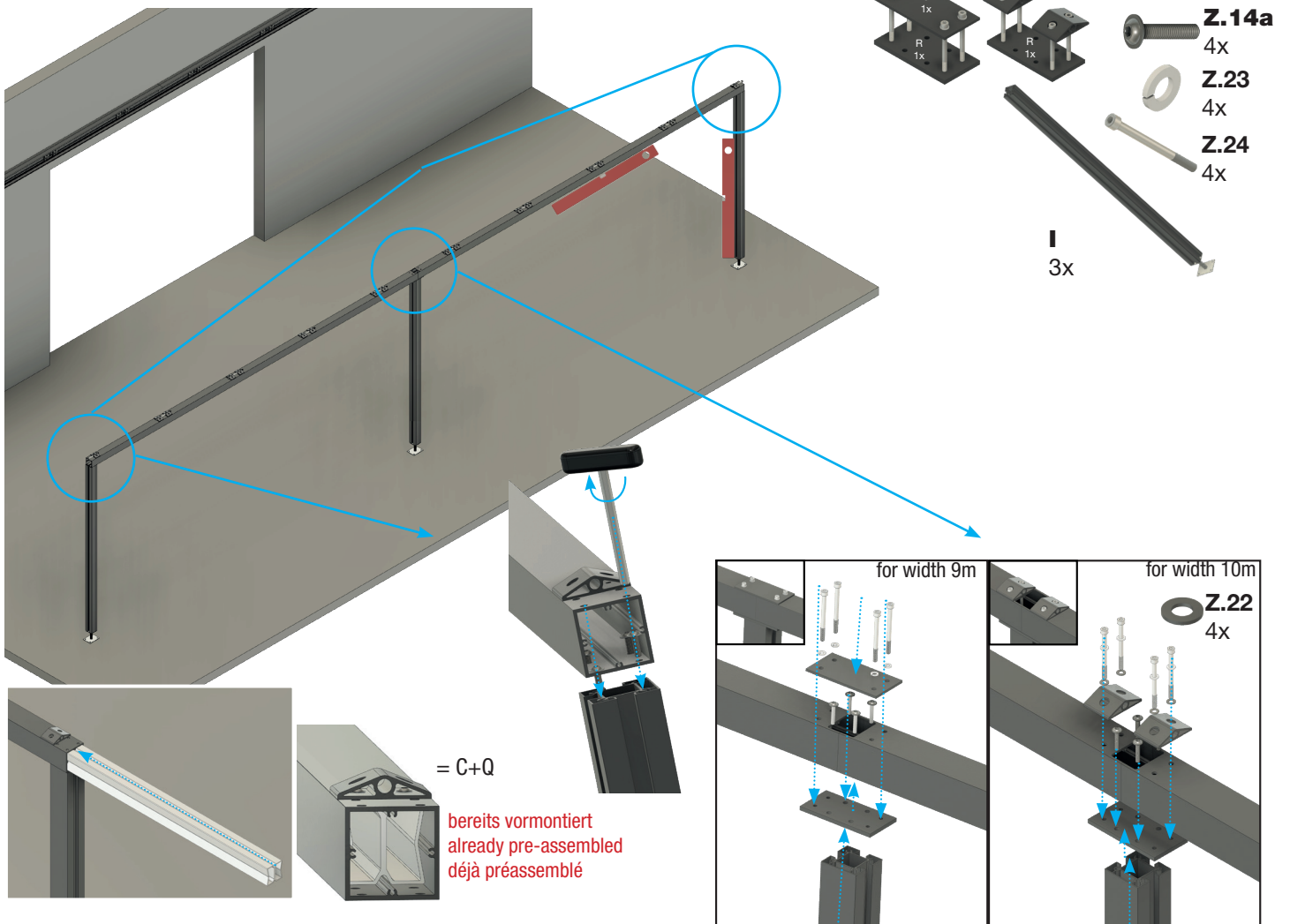

3.



J
2x



Z.19 A
8x

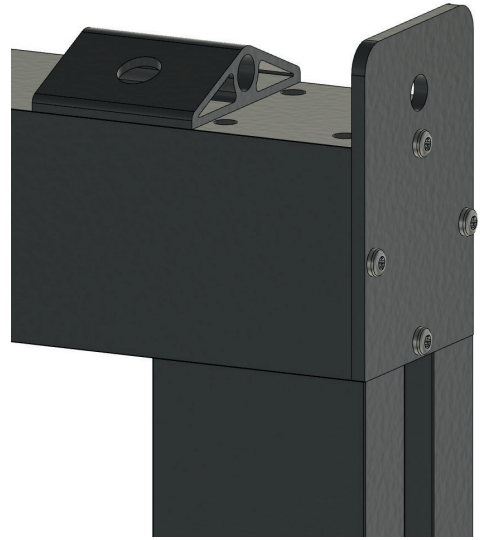
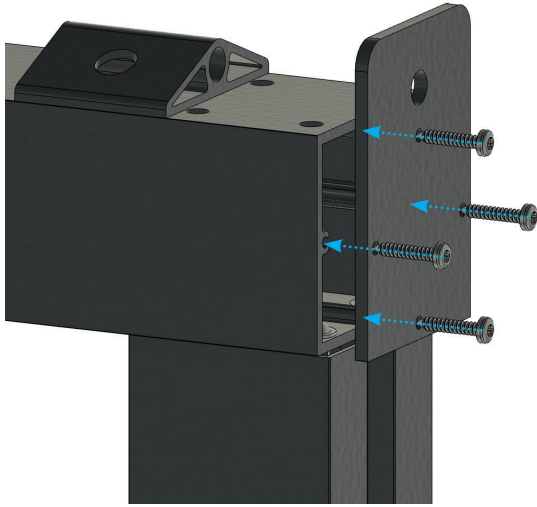

4.

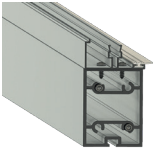

F
2x

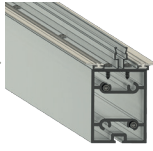

G
8x / 9x

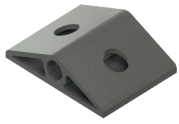

M
10x / 11x



Z.11
20x / 22x



Z.10
20x / 22x

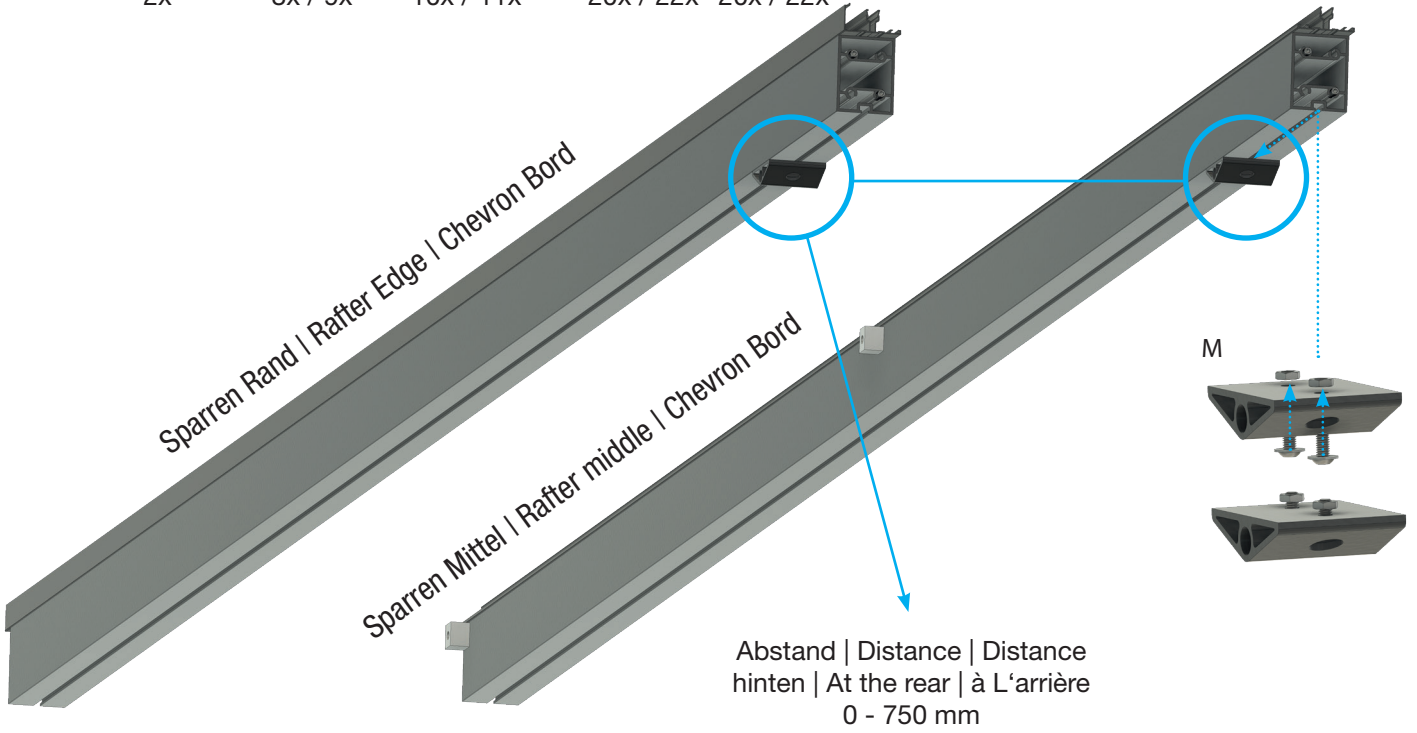

Nur bei 5m Tiefe | Only at 5m depth |
Seulement à 5m de profondeur | Alleen op 5m diepte |
500 - 750 mm

5.



F
1x
links | left |
à gauche



K
1x



Z.6
2x



Z.8
2x



Z.12
2x

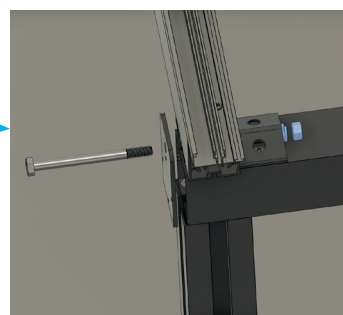
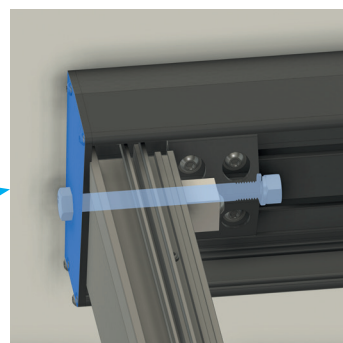
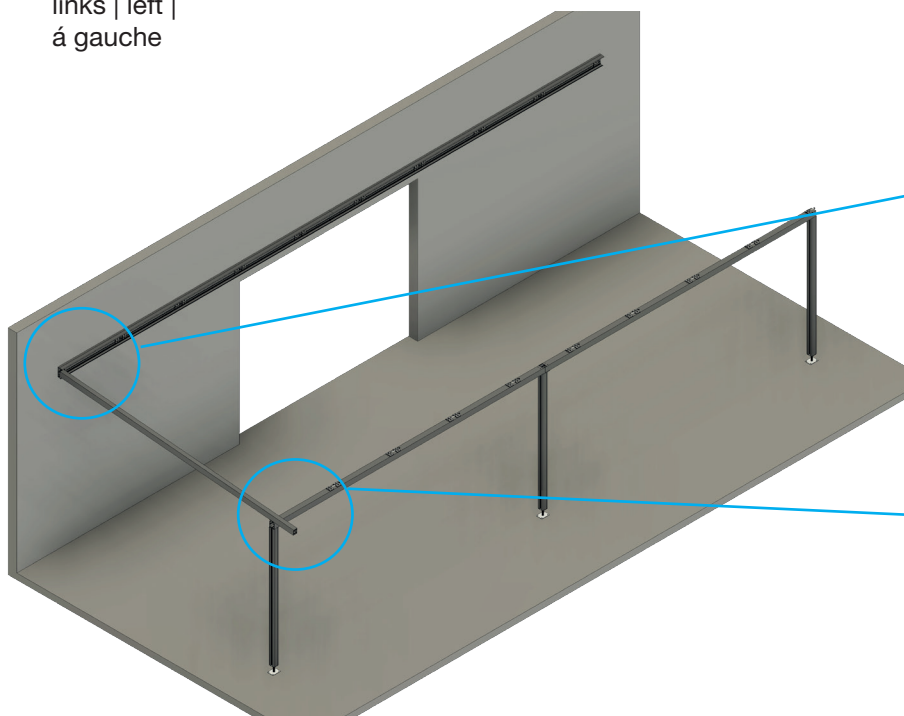

6.



G
1x



Z.6
2x



Z.12
2x





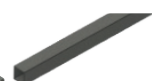

Z.9
2x

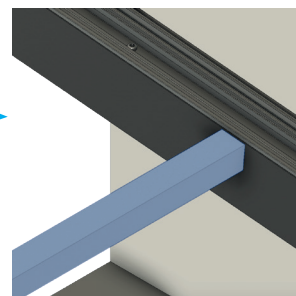
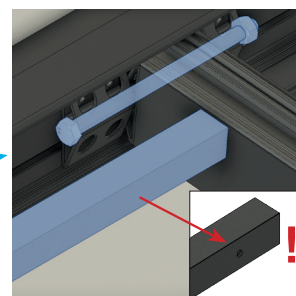
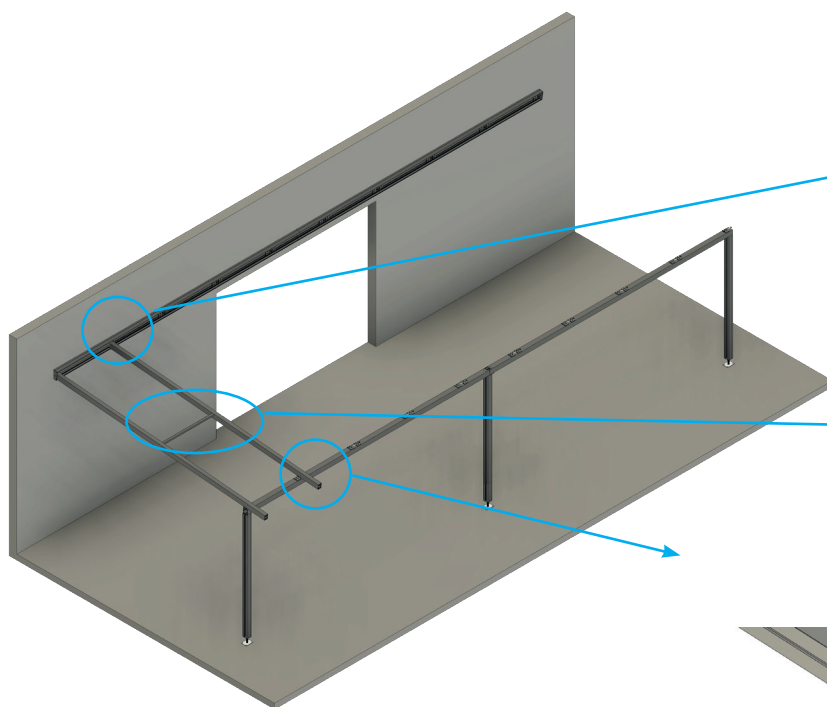

E
3m + 4m = 2x
5m = 3x





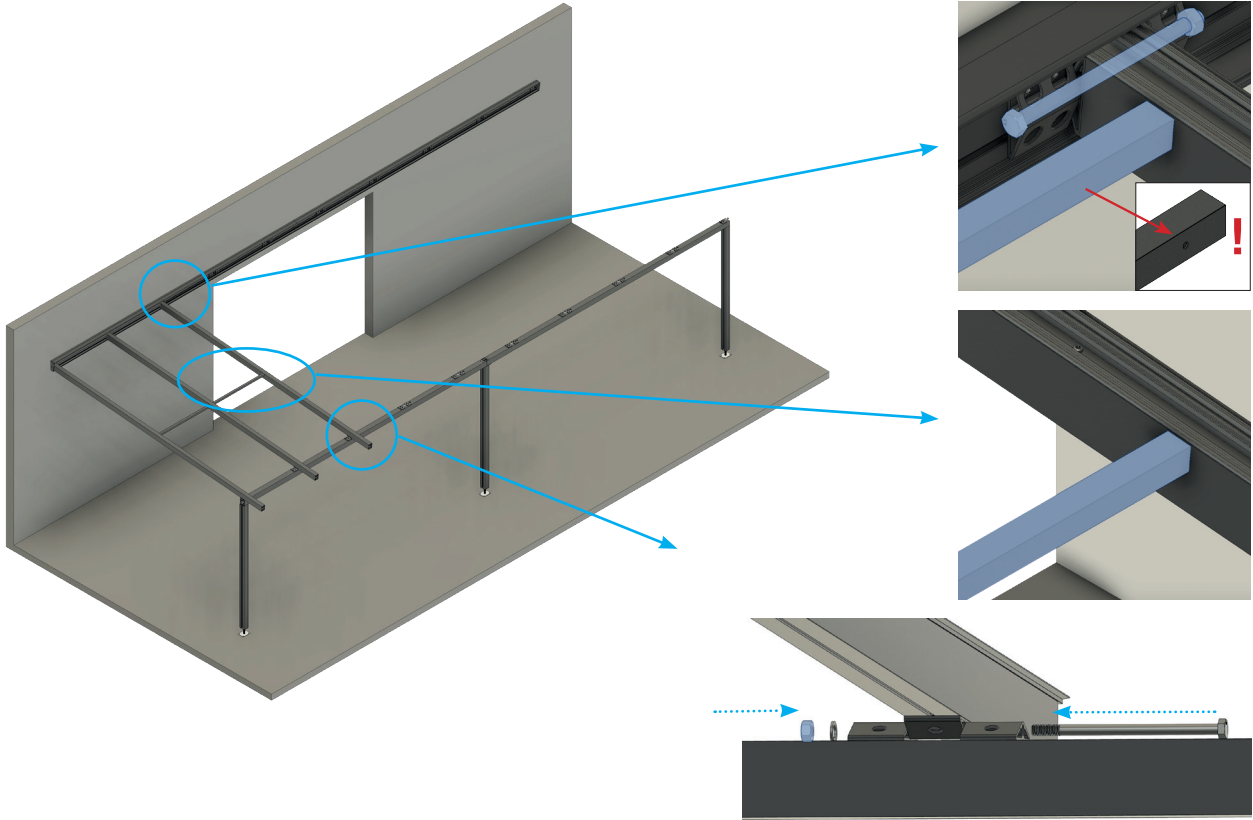

7.

- G**  1x
- Z.6**  2x
- Z.12**  2x
- Z.9**  2x
- E**  3m + 4m = 2x
5m = 3x





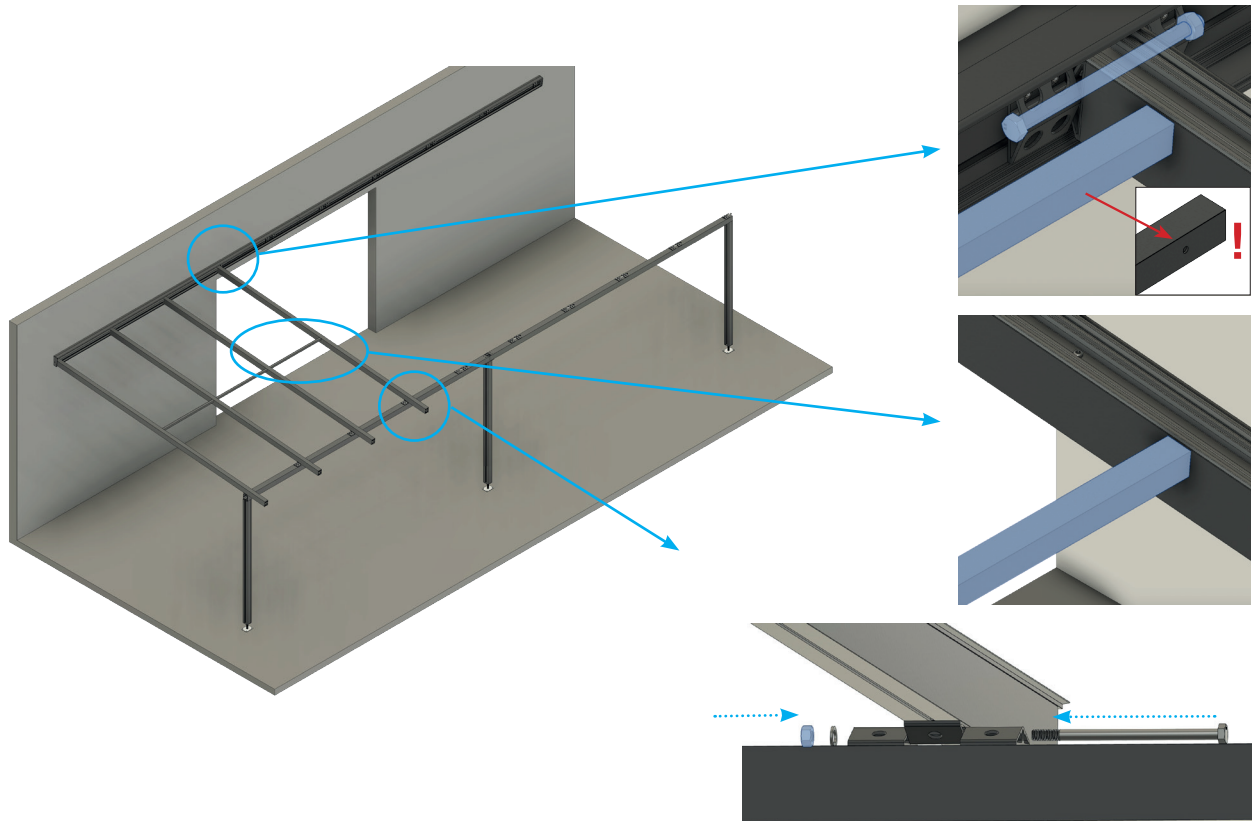

8.

- G**  1x
- Z.6**  2x
- Z.12**  2x
- Z.9**  2x
- E**  3m + 4m = 2x
5m = 3x





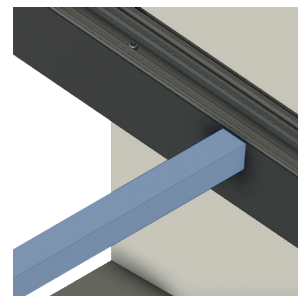
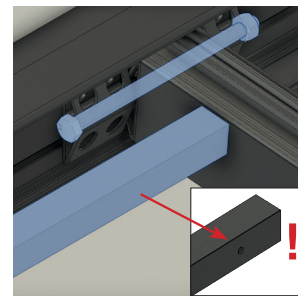
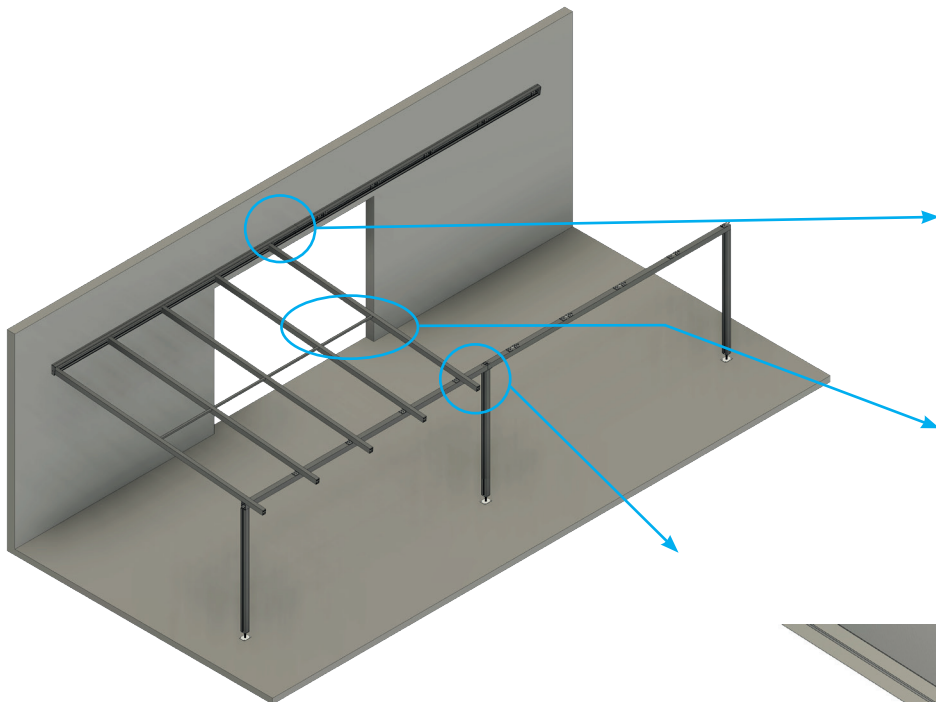

9.

- G**  1x
- Z.6**  2x
- Z.12**  2x
- Z.9**  2x
- E**  3m + 4m = 2x
5m = 3x





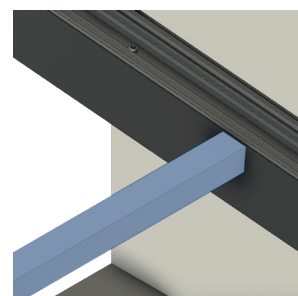
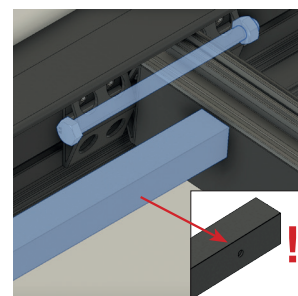
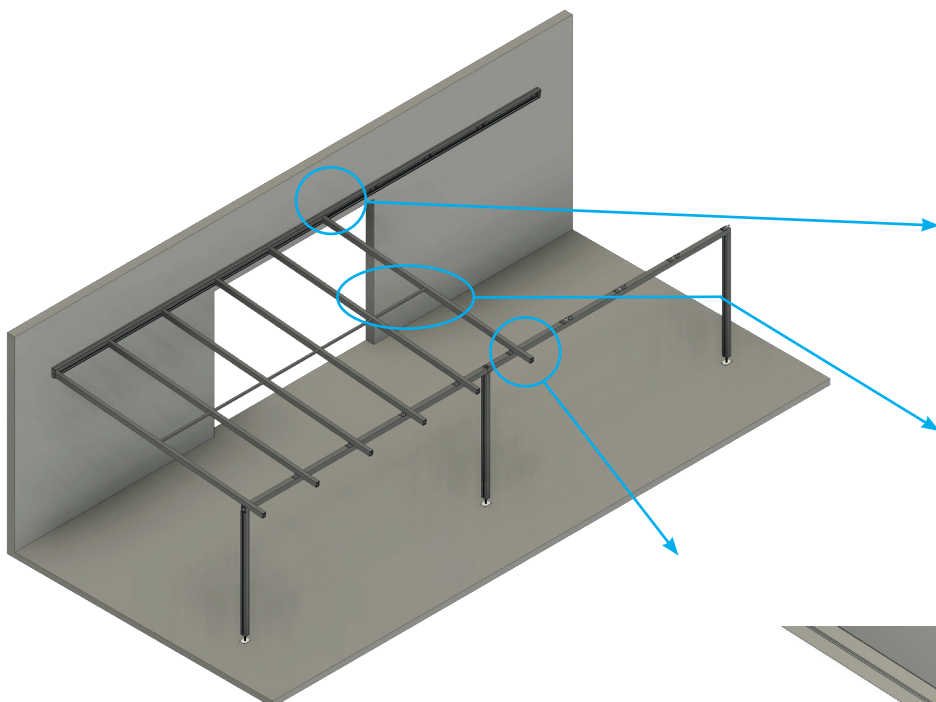

10.

- G**  1x
- Z.6**  2x
- Z.12**  2x
- Z.9**  2x
- E**  3m + 4m = 2x
5m = 3x





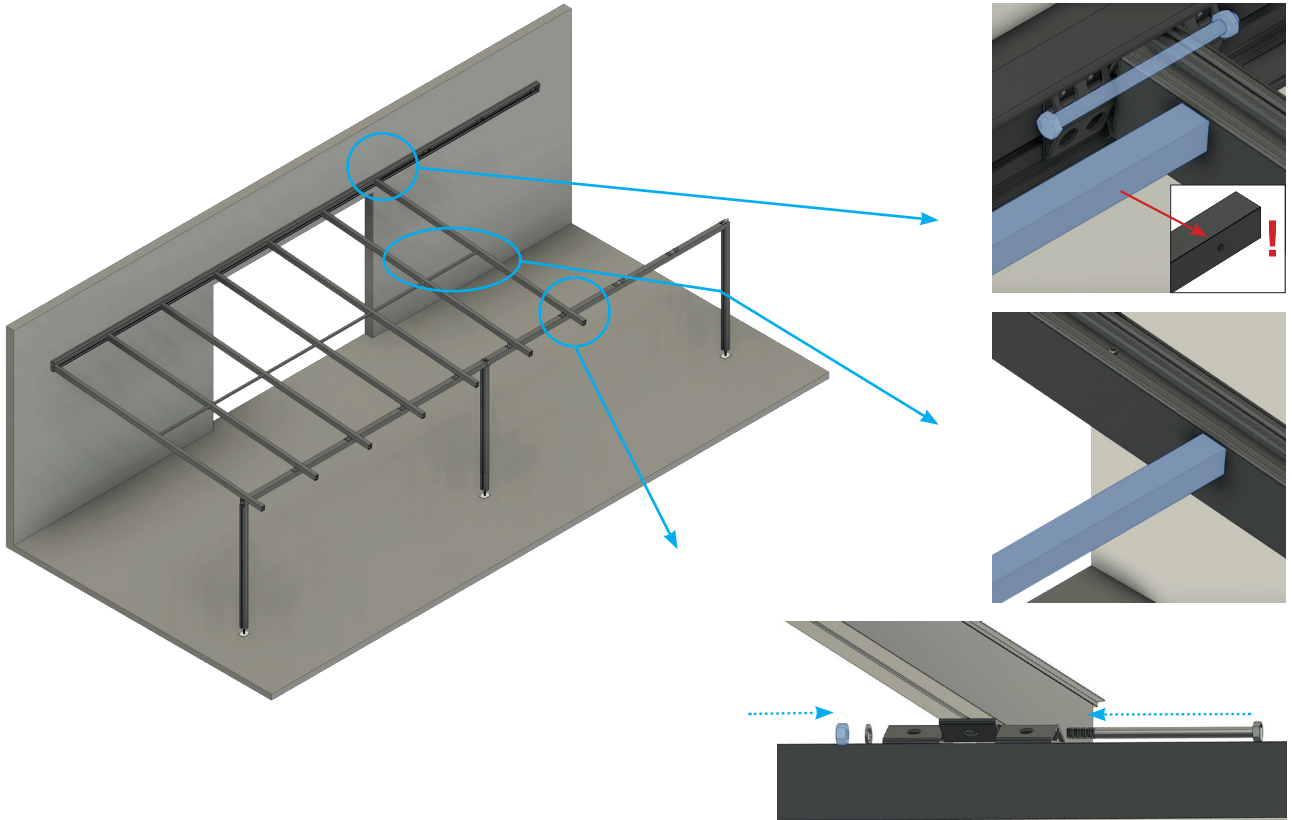

11.

- G**  1x
- Z.6**  2x
- Z.12**  2x
- Z.9**  2x
- E**  3m + 4m = 2x
5m = 3x



12.

- G**  1x
- Z.6**  2x
- Z.12**  2x
- Z.9**  2x
- E**  3m + 4m = 2x
5m = 3x

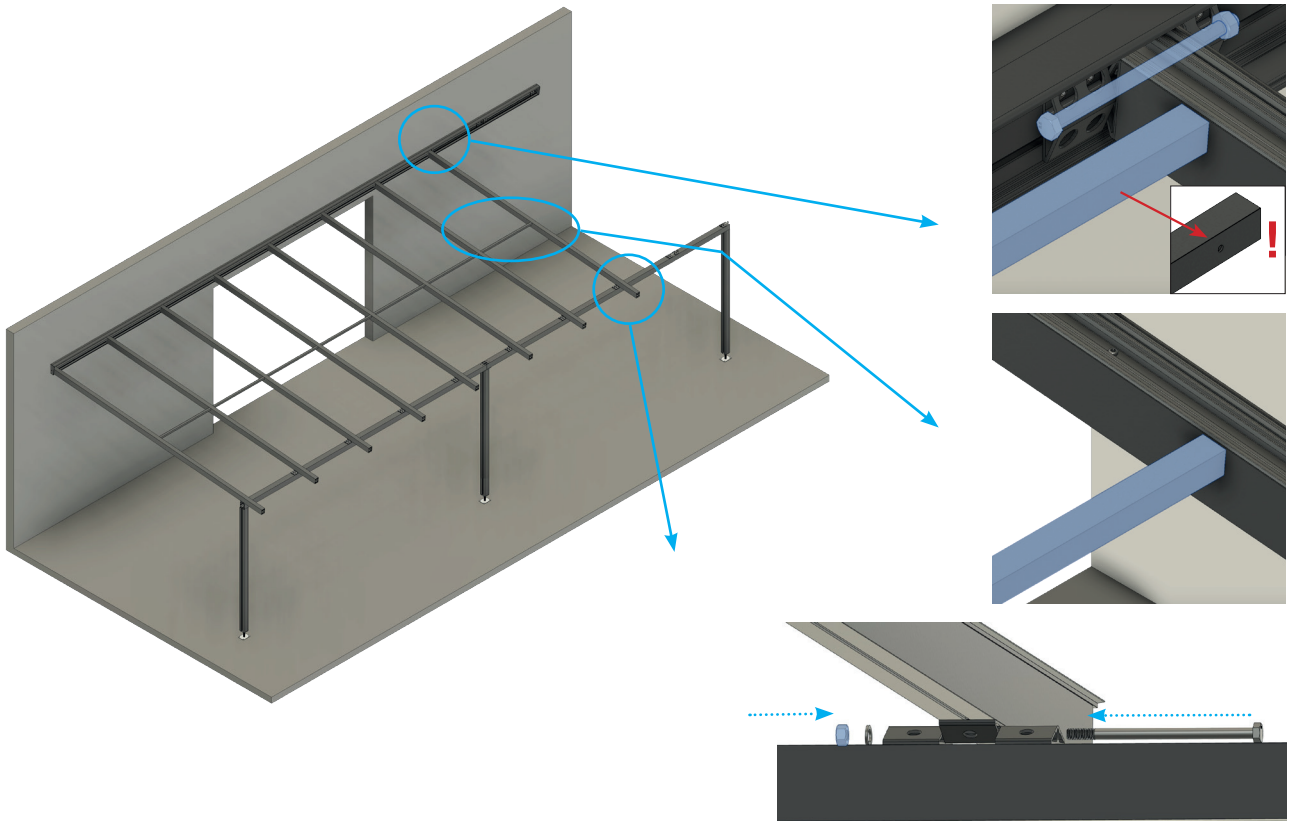

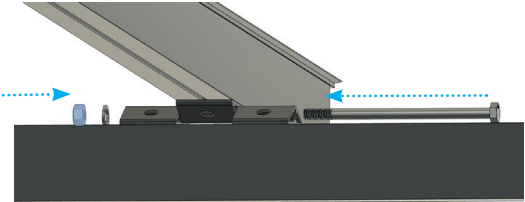
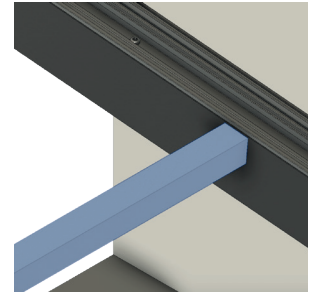
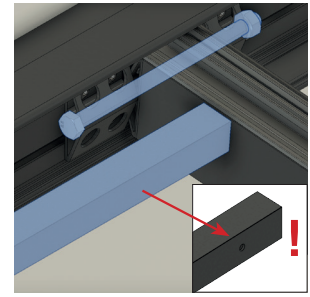
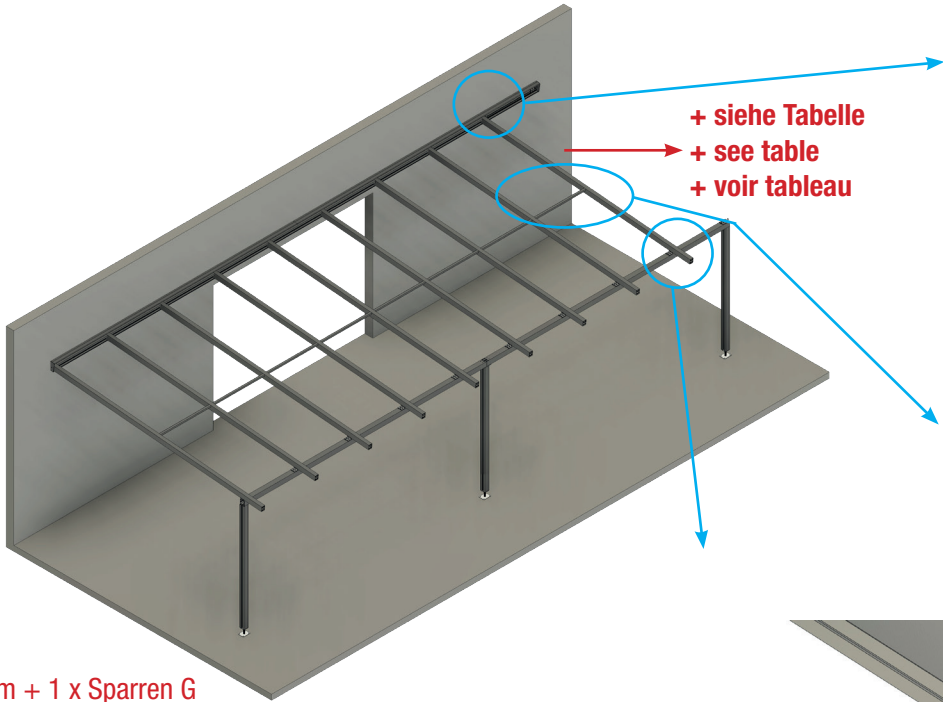
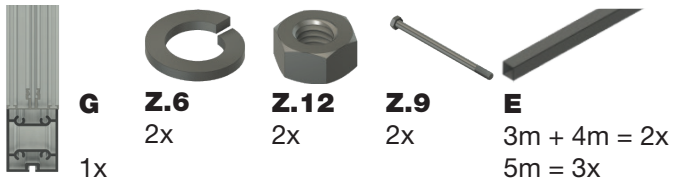

13.

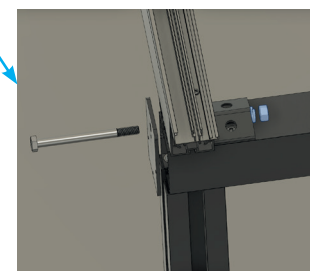
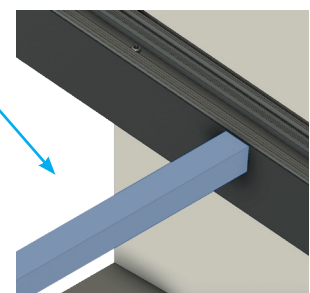
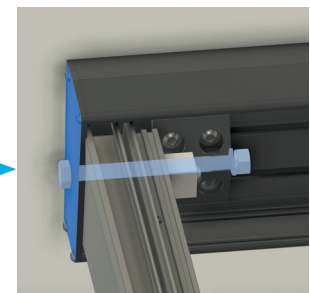
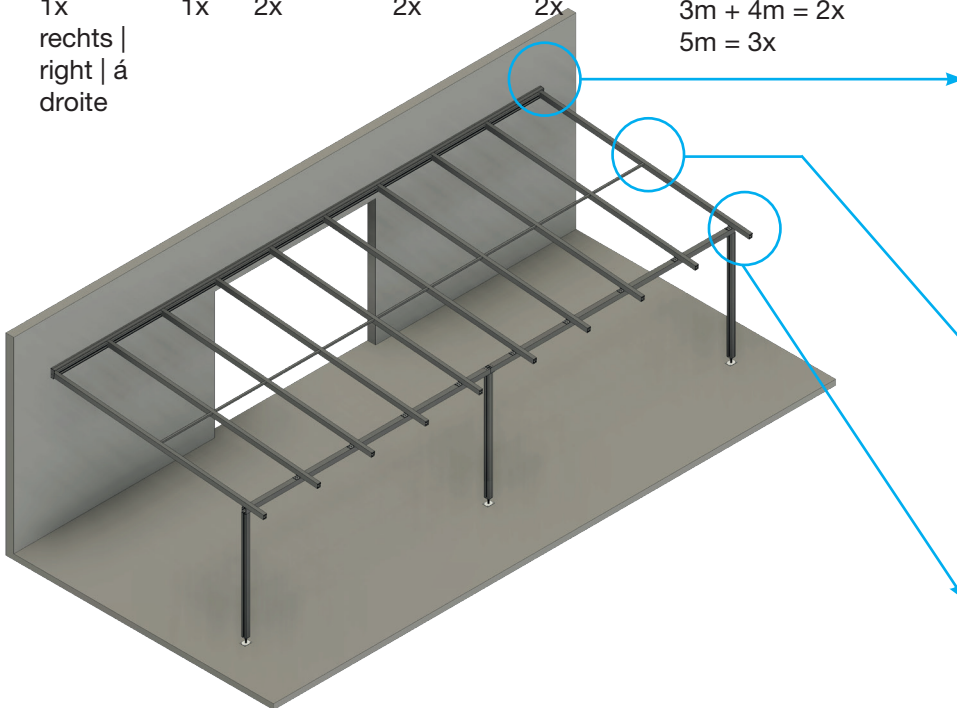
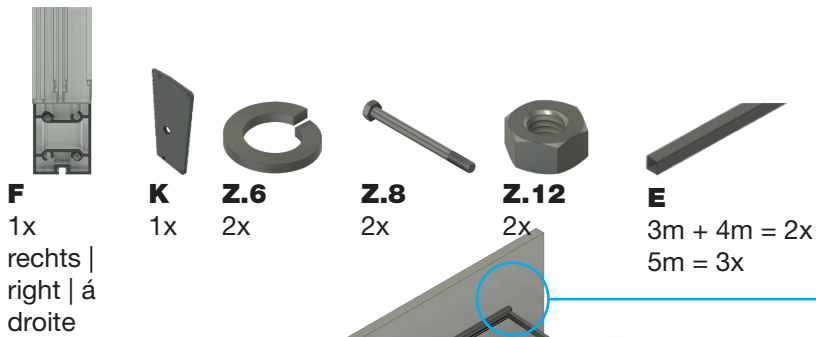

10m + 1 x Sparren G
 10m + 1 x rafter G
 10m + 1 x chevron G

14.



15. 
Z.19
8x

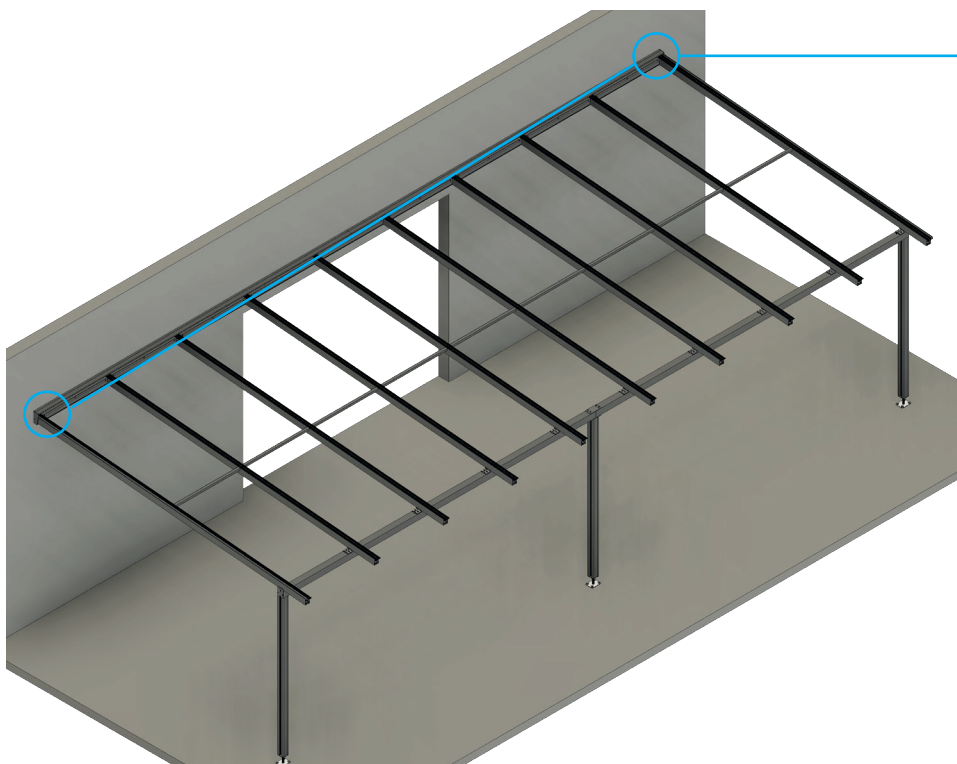

17.

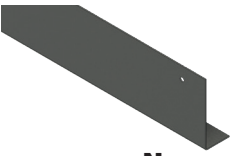

N
9 / 10 x



Z.19
27 / 30 x

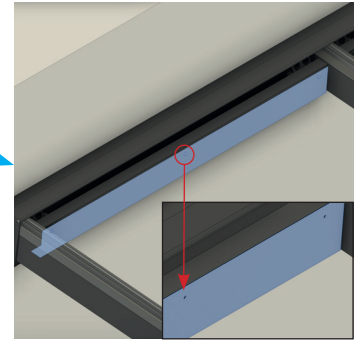
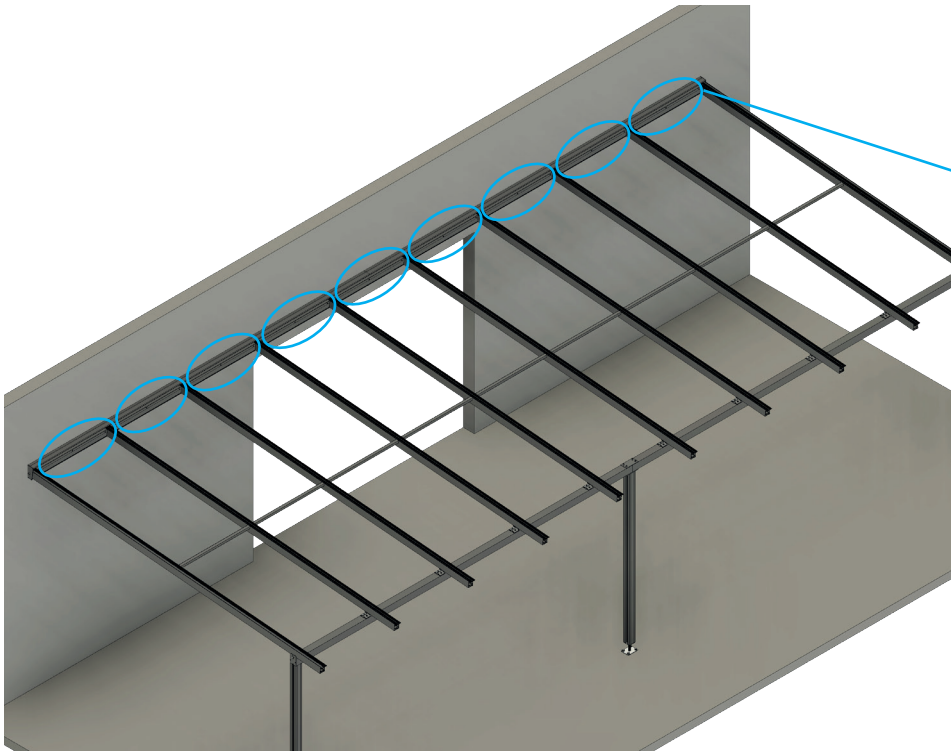

18.



Z.2
12x



Z.3
12x



Z.4
12x

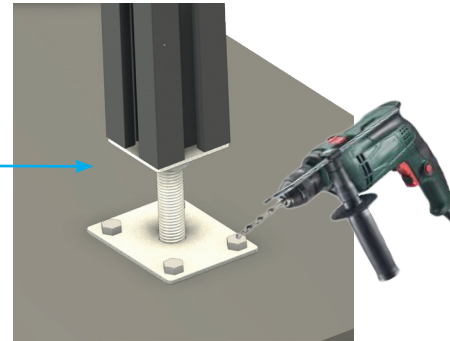
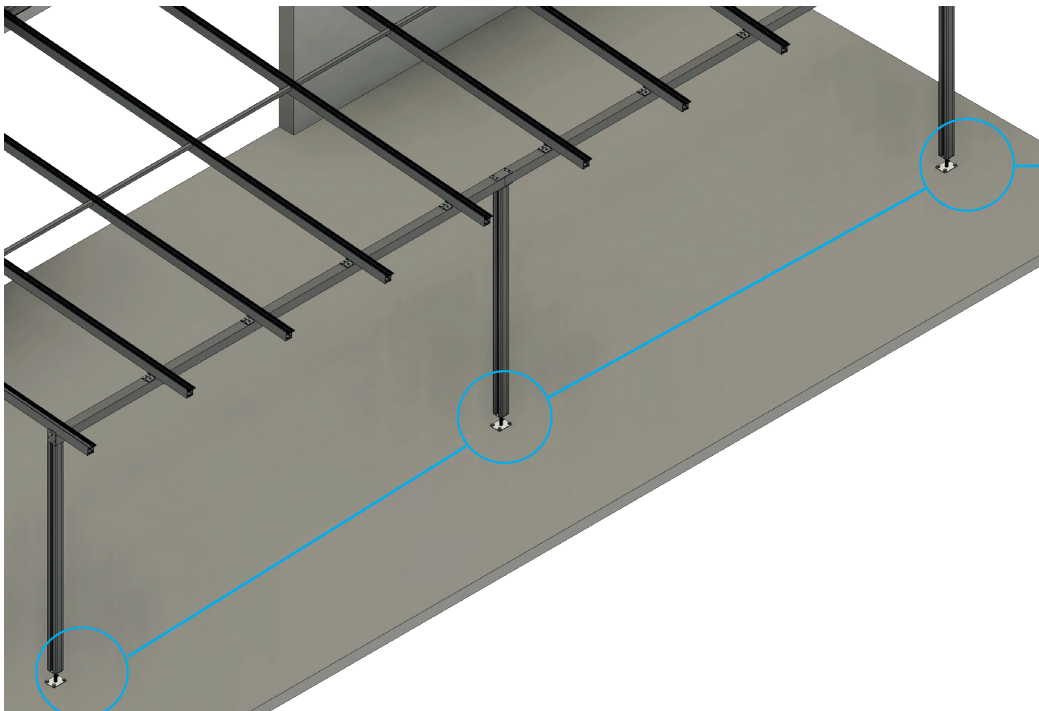

19.

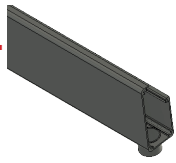

D
2 x



Z.16
20 / 22 x



L
2x



Z.19
8x



Z.25
1x



Z.26
3x



Z.27
3x



Z.28
6x

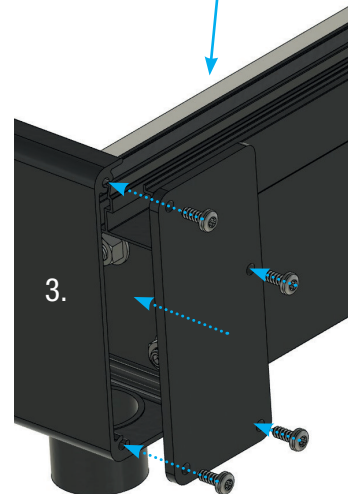
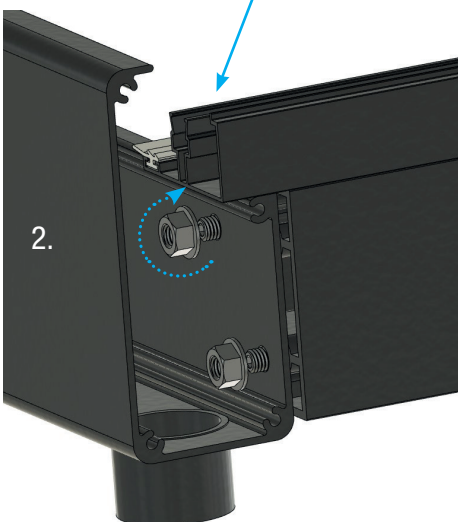
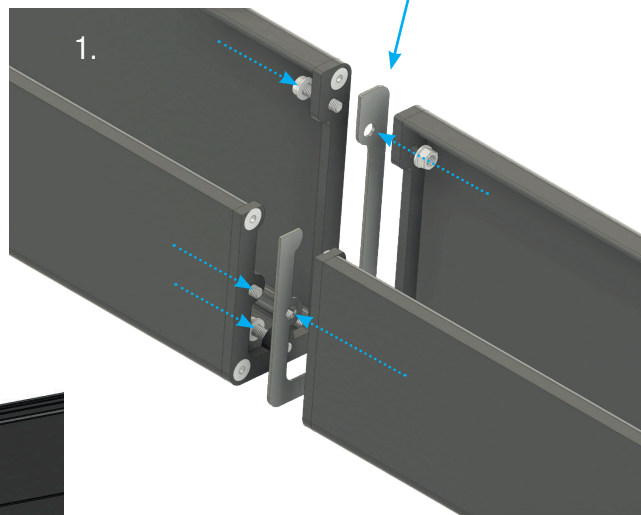
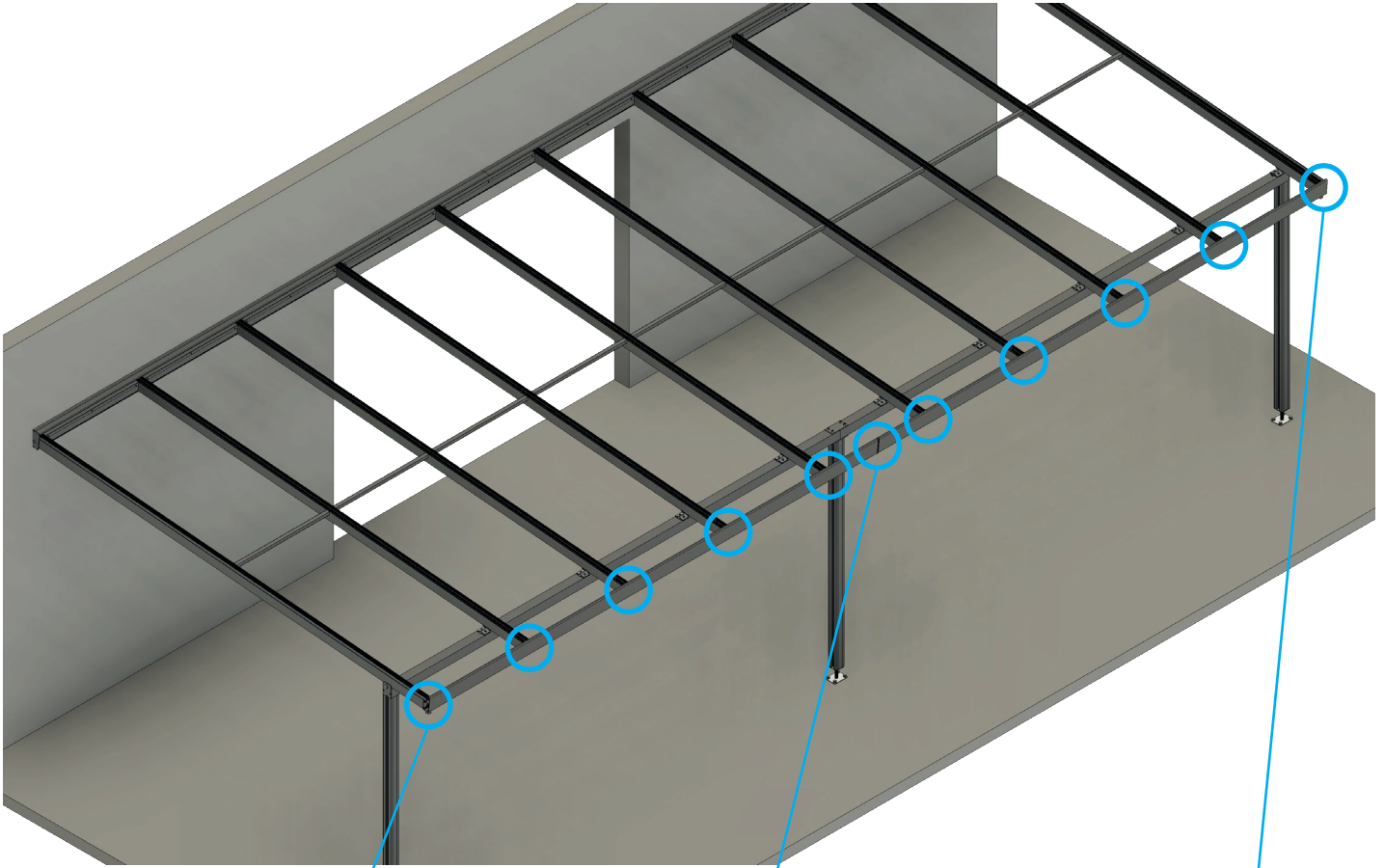

20.



A
9 / 10 x



O
18 / 20 x **Z.17**



Z.18

**(Nur bei Acrylplatten im Lieferumfang
enthalten /
Only for acrylic sheets in the included in
delivery /
Uniquement pour les plaques acryliques
de la gamme inclus dans la livraison)**

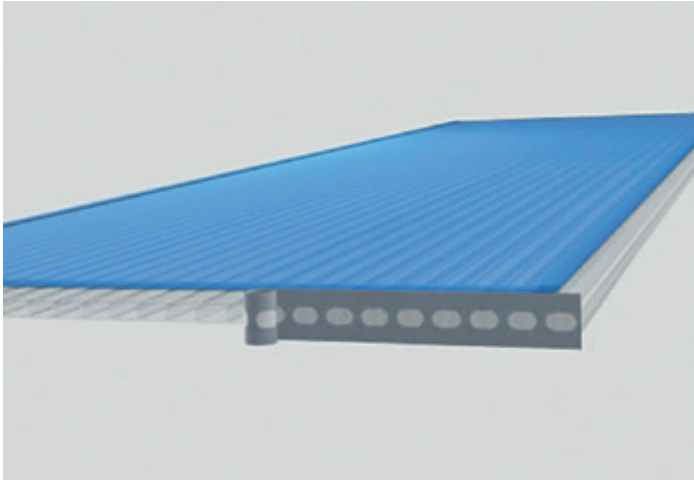

Zum Schutz vor eindringendem Staub und Schmutz kleben Sie die Stirnseiten der Platten mit dem Kantenverschlussband ab. Schlagen Sie dazu die Schutzfolie nur so weit wie nötig um.

To protect against dust and dirt, tape the front sides of the panels with the edge sealing tape. To do this, beat the protective film only as far as necessary.

Pour protéger contre la poussière et la saleté, collez les faces avant des panneaux avec la bande d'étanchéité de bord. Pour ce faire, battez le film protecteur que dans la mesure où c'est nécessaire.

Unsere Empfehlung!

Polycarbonatplatten: Traufe und First mit Membranband.
Acrylplatten: Band mit Membran an der Traufe und Band ohne Membran am First.

Our recommendation!

Polycarbonate sheets: eaves and ridge with membrane tape.
Acrylic panels: Band with membrane at the eaves and band without membrane at the ridge.

Notre recommandation !

Feuilles de polycarbonate : avant-toit et faîte avec bande de membrane. Panneaux en acrylique : Bande avec membrane à l'avant-toit et bande sans membrane au faîte.

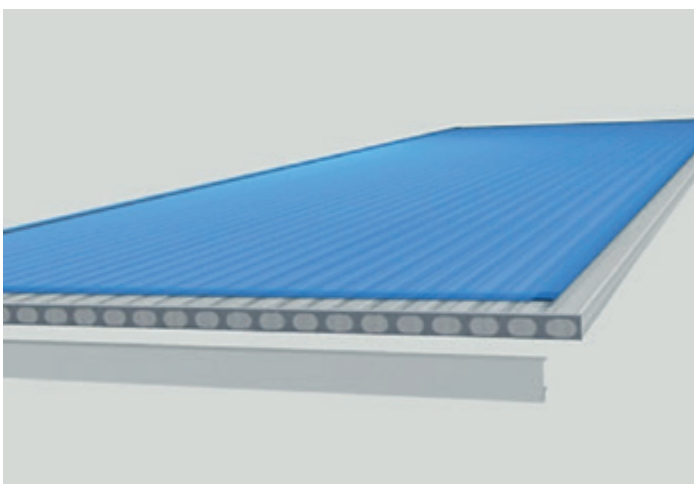

Stecken Sie nun die Alu-U-Abschlussprofile an den Stirnseiten auf. Achten Sie darauf, dass die gekennzeichnete Schutzfolie oben ist. UV-Schutz bei einseitig geschützten Platten! Die Tropfnase des Profils zeigt nach unten.

Now attach the aluminium U end profiles to the end faces. Make sure that the marked protective foil is on top. UV protection for panels protected on one side! The drip nose of the profile points downwards.

Fixez maintenant les profilés d'extrémité en aluminium sur les faces frontales. Veillez à ce que le film de protection marqué se trouve sur le dessus. Protection UV pour les panneaux protégés d'un seul côté ! Le nez d'égouttement du profilé est dirigé vers le bas.

21.



H
1x



Z.20
3m = 6x
4m = 8x
5m = 10x

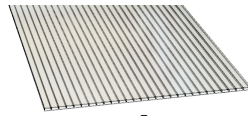

A
1x

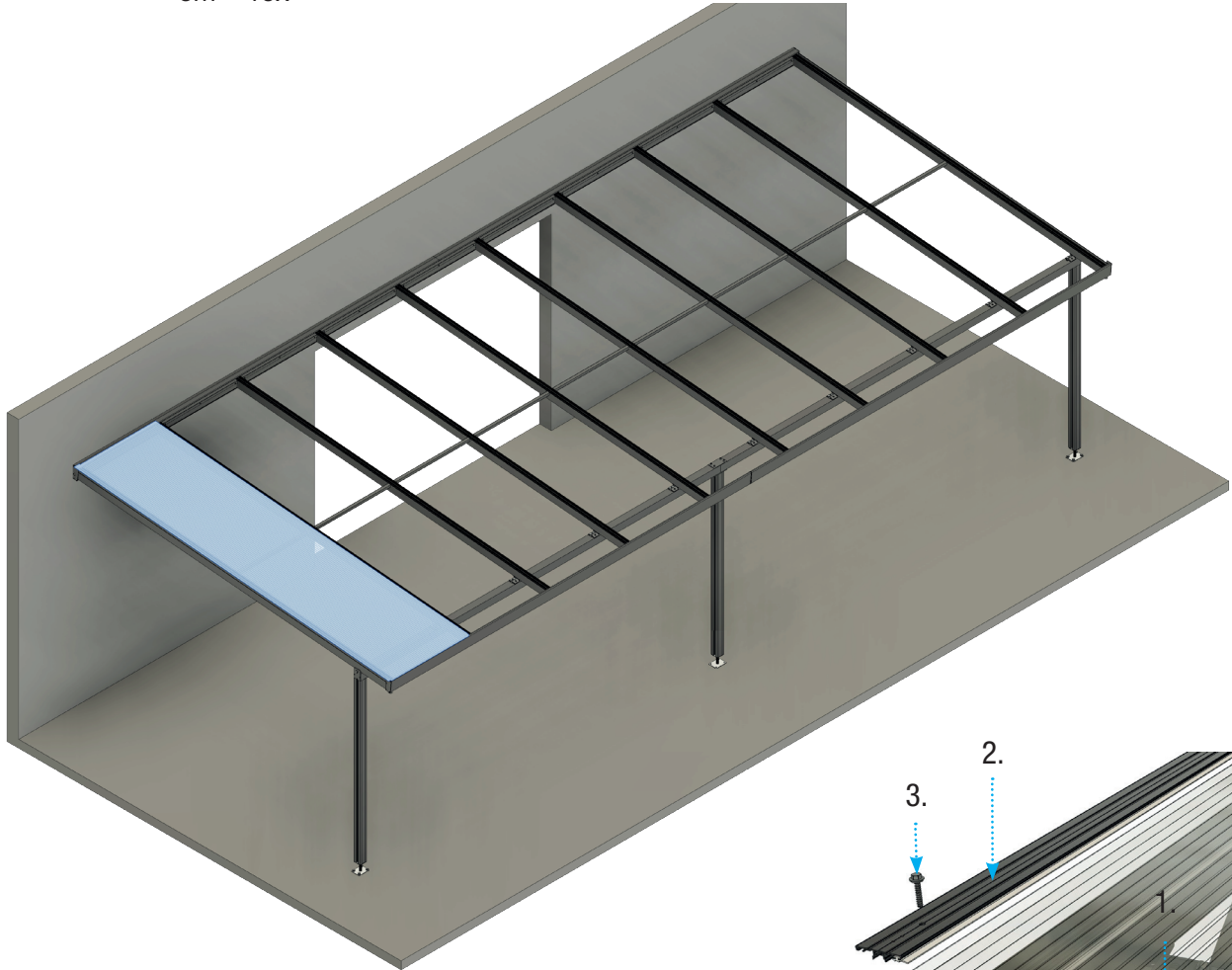

Legen Sie die erste Platte auf und richten Sie sie korrekt aus – beachten Sie auch hier die korrekte Ausrichtung der Schutzfolien. **Falls nicht vorgebohrt:** Profiloberteil alle 40 cm mittig vorbohren (Ø7 mm), die erste Bohrung erfolgt nach 6cm. Anschließend auflegen und mit dem Unterteil verschrauben.

Place the first panel on top and align it correctly - also make sure that the protective foils are aligned correctly. **If not predrilled:** Pre-drill the upper part of the profile in the middle every 40 cm (Ø7 mm), the first hole is drilled after 6 cm. Then place it on the surface and screw it to the lower part.

Placez le premier panneau sur le dessus et alignez-le correctement - veillez également à ce que les films de protection soient correctement alignés. **Si non pré-percé:** Pré-percer la partie supérieure du profilé au milieu tous les 40 cm (Ø7 mm), le premier trou est percé après 6 cm. Posez-le ensuite et vissez-le sur la partie inférieure.

Achtung: Deckel sind bereits vorgebohrt.

Attention: Lids are already pre-drilled.

Attention : les couvercles sont déjà pré-percés.

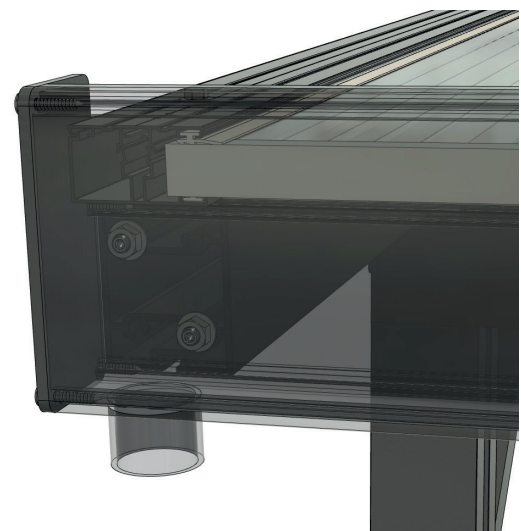
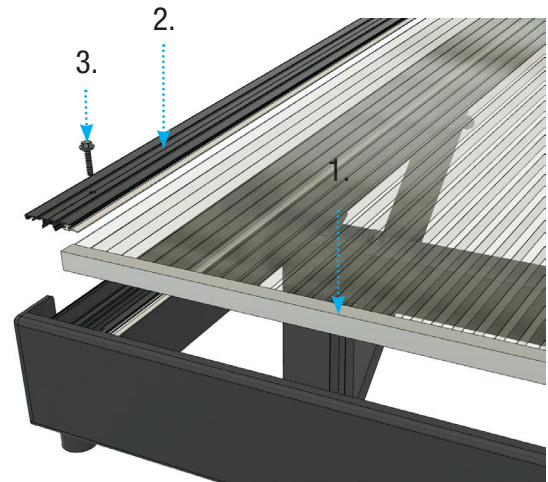

22.



H
9 / 10x



Z.20

3m = 54x / 60x
4m = 72x / 80x
5m = 90x / 100 x



A
9 / 10x

Achtung: Deckel sind bereits vorgebohrt.

Attention: Lids are already pre-drilled.

Attention : les couvercles sont déjà pré-perçés.

2. Platte / Plate

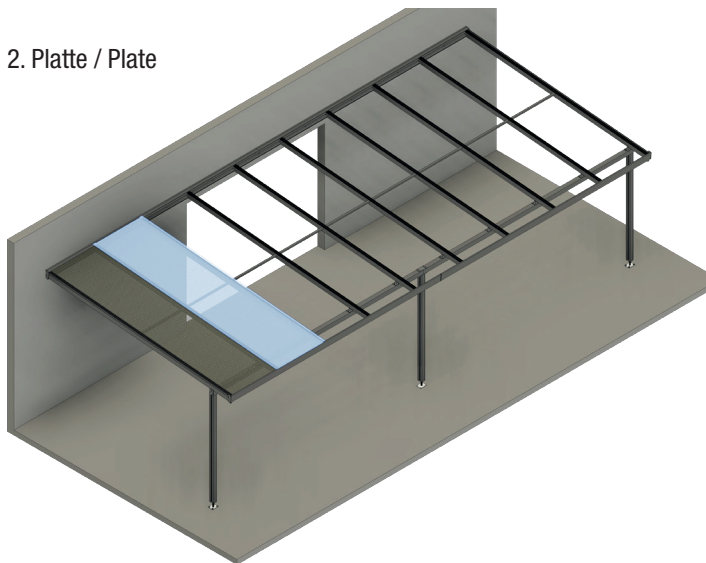

3. Platte / Plate

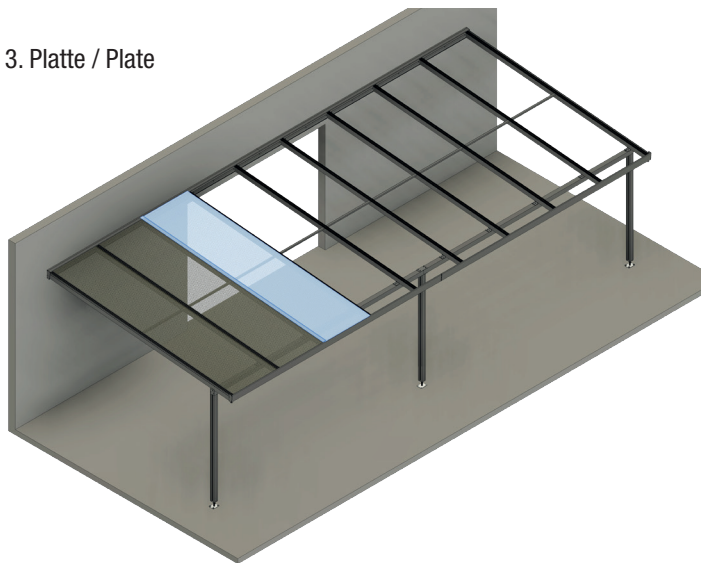

4. Platte / Plate

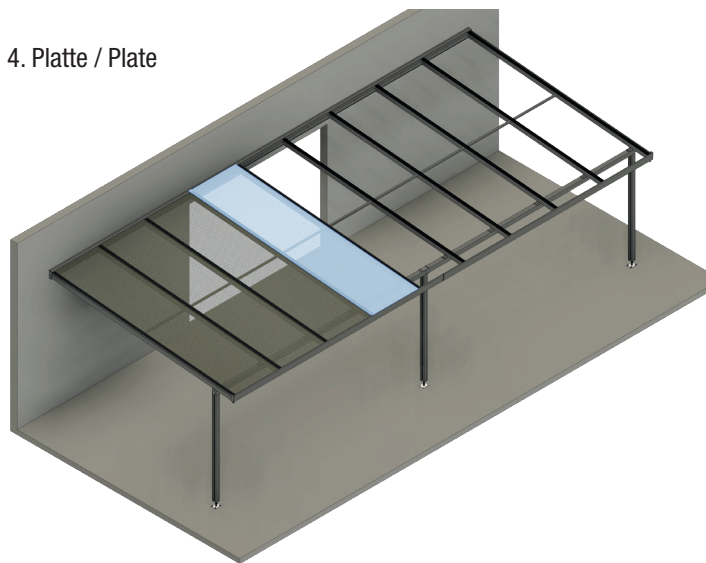

5. Platte / Plate

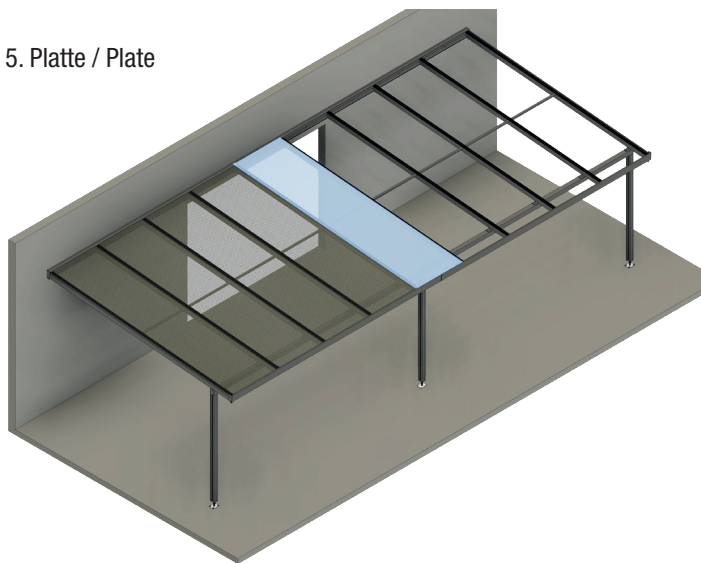

6. Platte / Plate

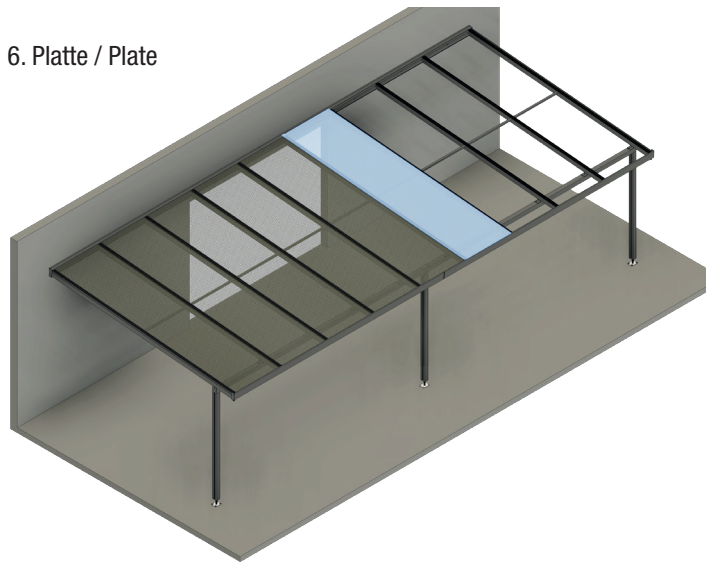

7. Platte / Plate

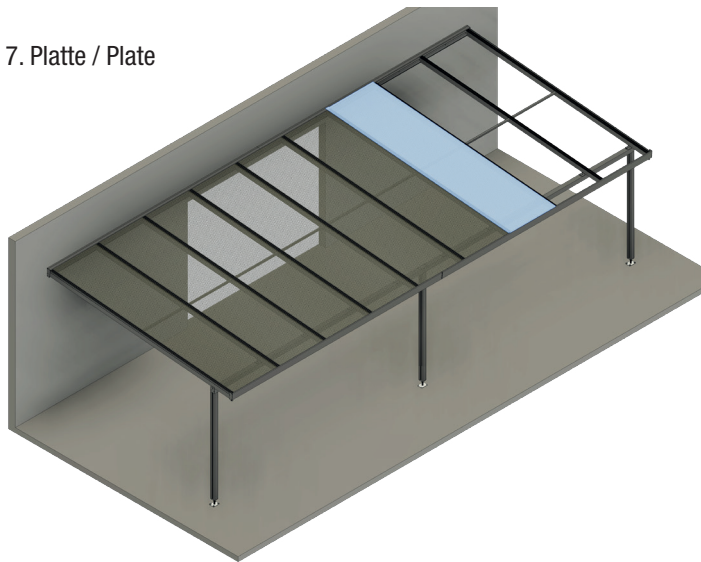

8. Platte / Plate

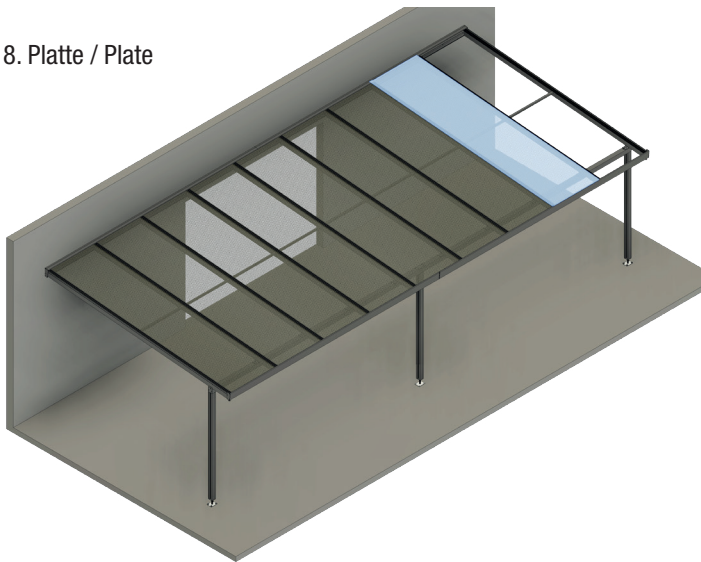

9. Platte / Plate

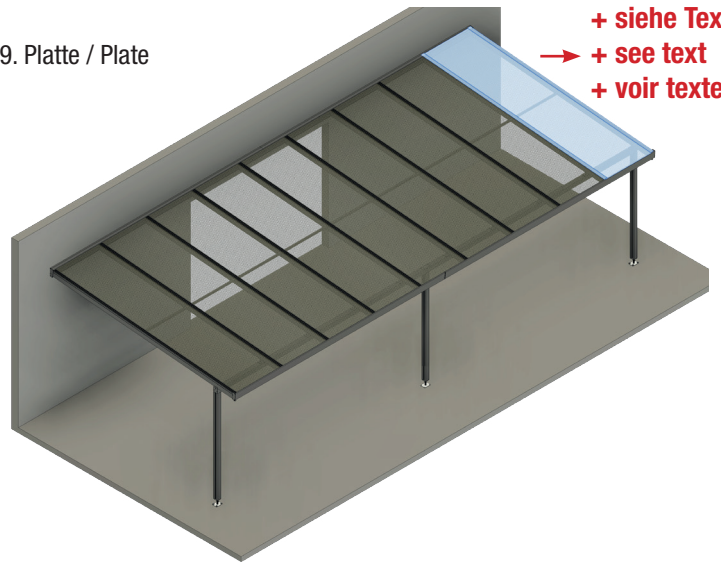

+ siehe Text
→ + see text
+ voir texte

Terrassendachbreite 10 m = 10 Platten

Terrace roof width 10 m = 10 panels

Largeur du toit de la terrasse 10 m = 10 panneaux

Montieren Sie in der gleichen Art und Weise die restlichen Platten und verschrauben Sie diese mit den Deckeln wie im Schritt 18. Ziehen Sie anschließend die Schutzfolien ab.

Assemble the remaining plates in the same way and screw this with cover together as in step 18. Then remove the protective films.

Monter les autres plaques de la même manière et visser ce couvercle ensemble comme à l'étape 18. Retirez ensuite les films de protection.

23.



Z.1
4x

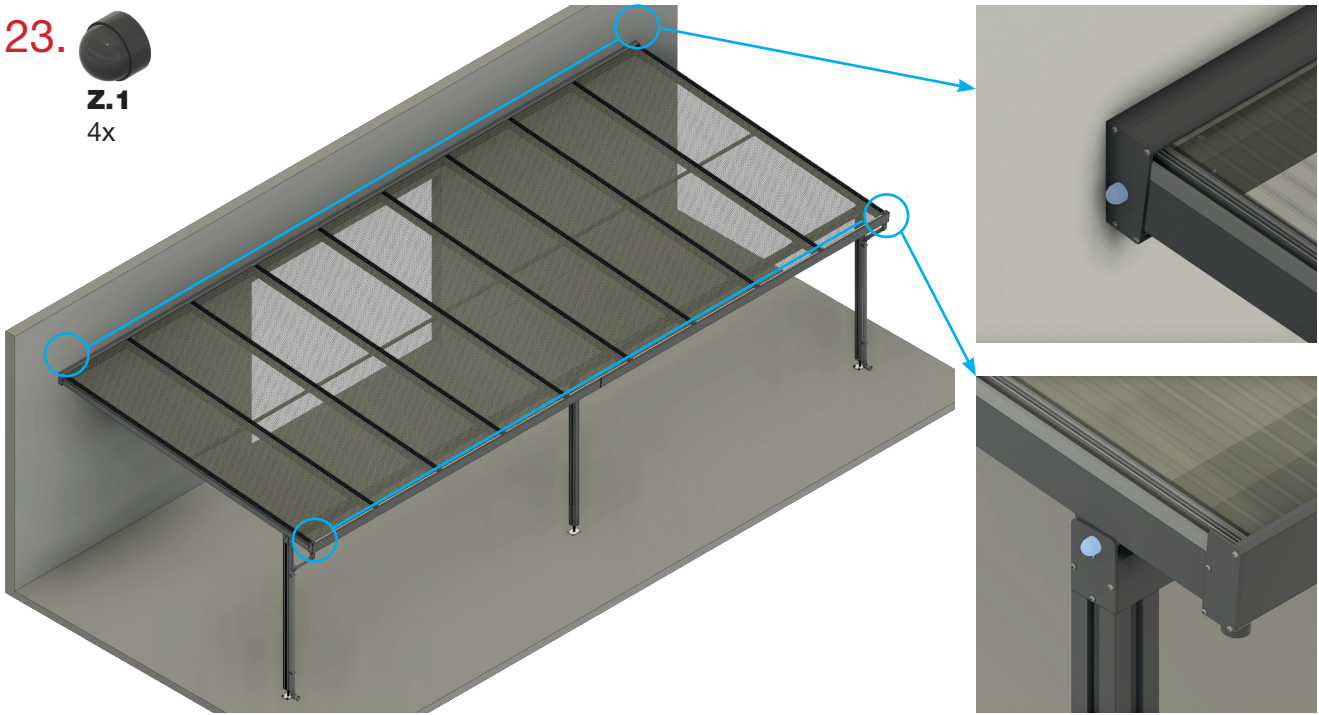

24.

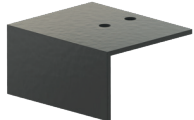

Z.21
10x
11x



Z.19
20x
22x

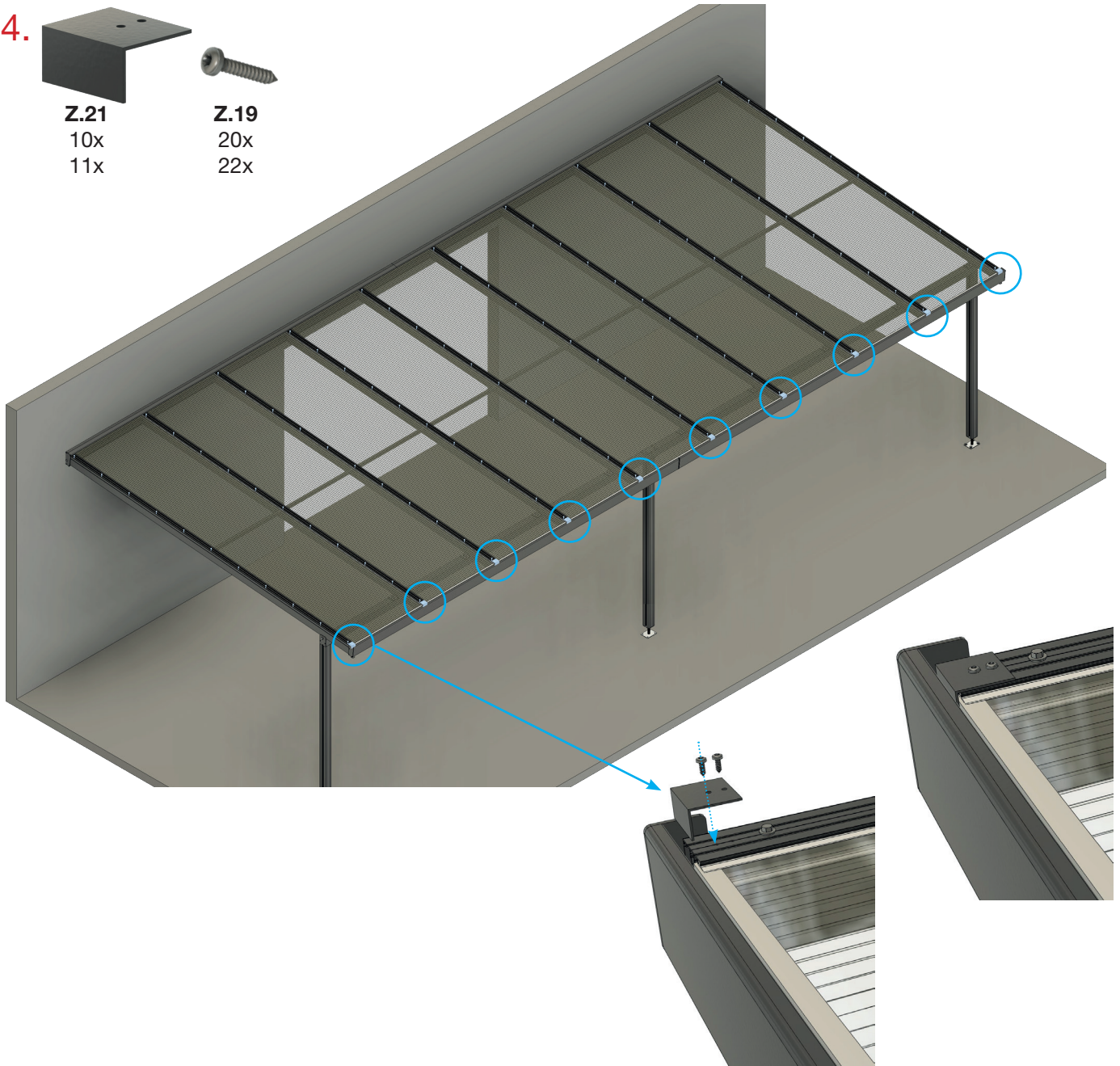

25.

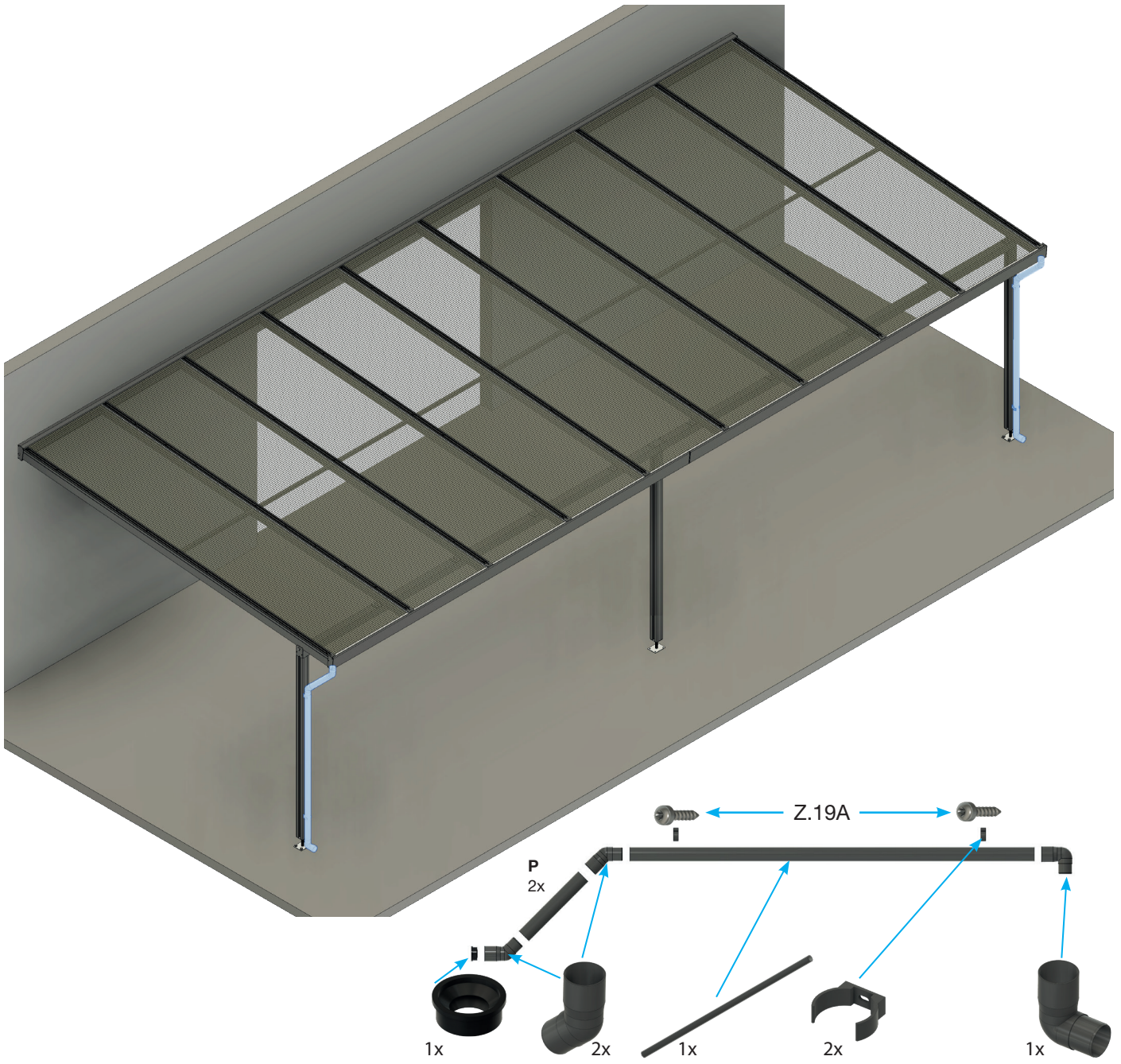

Produktübersicht / Overview of product range / Gamme de produits



Hohlkammerplatten
Twinwall sheets



Profilplatten
Profile plates



Vordächer
Canopies



Terrassendächer
Terrace roofs



Paneele
Twinwall panels



Ebene Platten
Polystyrene sheets



Bitumenwellplatten
Corrugated bitumen sheets



Noppenbahn
Dimpled Membrane

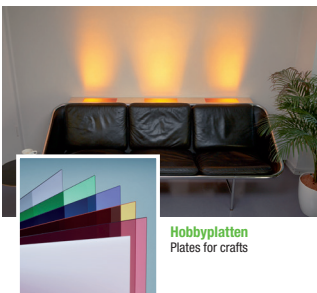

Hobbyplatten
Plates for crafts

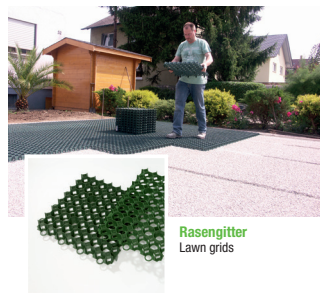

Rasengitter
Lawn grids



Gartenprodukte
Garden products

... und vieles mehr!
...and much more!



Gutta Werke GmbH
Bau- und Heimwerkerprodukte
Bahnhofstraße 51-57
D-77746 Schutterwald
Telefon 0781 6090
Telefax 0781 6093200
info@gutta.com

www.gutta.com



www.scobalit.de

Scobalitwerk Wagner GmbH
Zürnkamp 27
D-21217 Seevetal-Meckelfeld
Telefon 040 2190210
Telefax 040 70011446
seevetal@scobalit.de

Scobalitwerk Wagner GmbH
Fichtenstraße 18
D-56584 Anhausen
Telefon 02639 962570
Telefax 02639 962571
anhausen@scobalit.de

Scobalitwerk Wagner GmbH
Hermann-Ilgen-Straße 7
D-04808 Wurzen
Telefon 03425 814708
Telefax 03425 814709
wurzen@scobalit.de

Scobalitwerk Wagner GmbH
Industriepark 3
D-97273 Kürnach
Telefon 09367 98440
Telefax 09367 984429
kuernach@scobalit.de

Scobalitwerk Wagner GmbH
Bahnhofstraße 51-57
D-77746 Schutterwald
Telefon 0781-9907900
Telefax 0781-6093207
offenburg@scobalit.de